

Saltfork Craftsmen Artist-Blacksmith Association

December 2012



Lights for Pawnee Bill's Ranch
Richard Dyers' work

Article on page 5

Saltfork Craftsmen
Artist-Blacksmith Association
Officers and Directors

President: Gerald Brostek 918-687-1927
205 N. Anthony
Muskogee, Ok. 74402
Gerald.brostek@sbcglobal.net

Vice-President/events: 580-688-3555
David Seigrist
P.O. Box 163 Hollis, Ok 73550
dseigrist2004@yahoo.com

Sec-Treas. Dan Cowart 918-440-0653
10380 N. 4010 Road
Wann, Ok 74083
ddcowart@gmail.com

Director/Editor: Diana Davis 580-549-6824
23966 NE Wolf Rd.
Fletcher, Ok 73541
Diana.copperrose@gmail.com

Director/cones: Byron Donor 405-650-7520
6520 Alameda, Norman Okla.
byrondoner@earthlink.net

Director/swage blocks: Bill Kendall 918-742-7836
1756 E. 59th St Tulsa Ok. 74105
wwkendall@aol.com

Director: Don Garner 580-661-2607
23713 E. 860. Rd
Thomas Ok. 73669

Assignments:

Webmaster:
Dodie O'Bryan
Pawnee, Ok
scout@skally.net

Workshop Coordinator:
Gerald Franklin 580-467-8667
Rt. 3 Box 239J, Duncan, Ok 73533
franklin@myrhinomail.com

(Gerald Franklins stepping down as workshop coordinator in 2013. We need volunteer to take this assignment. Contact board member is interested)

The Saltfork Craftsmen Artist-Blacksmith Association, a non-profit organization of amateur and professional artist and craftsmen, publishes this newsletter monthly. Our purposes are the sharing of knowledge, education and to promote a more general appreciation of the fine craftmanship everywhere. We are a chapter of the Artist-Blacksmith Association of North America.

Material from this newsletter may be freely copied without permission for non-profit purposes. Please credit the author and this publication.

Visit our Saltfork Craftsmen Website:
www.saltforkcraftsmen.org

Notes from the Editor:

Hope everyone had a wonderful Thanksgiving and got out and worked off some of that turkey and dressing by forging up some nice Christmas gifts.

There is a correction to the date on the workshop this month. It is scheduled for Dec. 29th not the 31st as reported. Workshops are held in months that have a 5th Saturday so we don't interfere with a regular region meeting.

The new year is fast approaching and we need to fill our meeting calendar. If you would like to host a meeting, please check out the list and pick a meeting date that is open in your region and fill out the form and mail it to me. Meeting are first come first served.

With cooler weather comes a slowdown in the number of events that want a blacksmith, so it is the ideal time to clean the shop, sell any excess tools and heat of the forge and practice our skills. So with that in mind I hope everyone has a Wonderful Holiday Season and Merry Christmas.

From the Prez.....



Hope everyone had a great Thanksgiving and now able to do some forging work on some new projects. I have been wanting to create something using my newly acquired knowledge that I gained from our 2012 Conference Demonstrators. For those who haven't heard, David Segrist has Clay Spencer lined up for our 2013 Conference. Clay has been blacksmithing for nearly all his lifetime. I'm sure we will all learn some from him.

If you haven't signed up for hosting a Regional meeting for 2013 yet, now is the time to do so by filling out the Host Form in the newsletter and getting it to Diana.

At our regional meetings we sometimes get new, first time members and often guests who are interested in our craft. I would like to suggest that if you see any of these folks show up at your meeting that you make them feel welcome and invite them to watch as you or any other experienced members in attendance put on a demonstration showing how to make something. Even if it is a review of some of the basics, like drawing out, upsetting, bending etc. I myself will be demonstrating how to make an outdoor cooking tri-pod at the Northeast Regional Meeting in May at the Fort Gibson Historic site.

Gerald Brostek

“God bless our Craftsmen and Craftswomen”

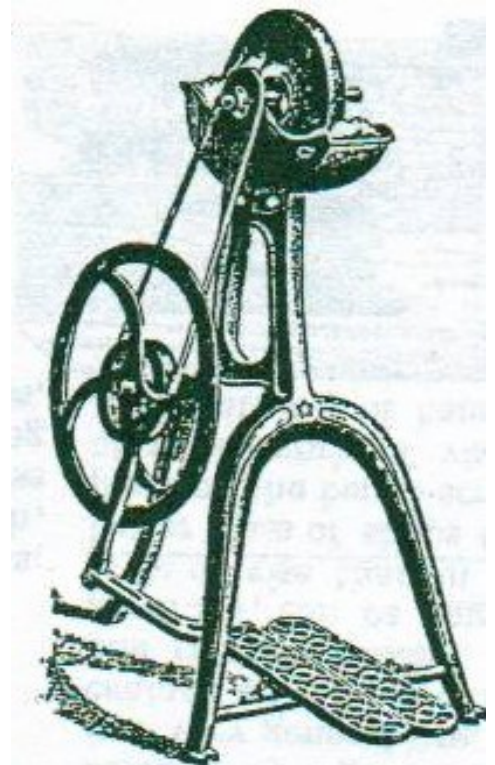

Year end meeting dates. We are getting closer to the end of 2012. Here are the meetings we have coming up.

November:

SE region:

November 3, 2012

Host: Open

Phone #:

NE region:

November 10, 2012

Host: Matt Goyer

Phone # 918-272-8424

Trade item: cross

Lunch: lunch provided, bring a side dish

SC region:

November 17, 2012

Host: Bill and Diana Davis

Phone #: 580-549-6824

Trade item: candle holder

NW region:

November 24th 2012

Host: Roy Bell (no host form submitted)

Lunch: Provided, bring a side dish

Phone #: 580-309-4513

Trade item: bell

Call for location.

December:

SE region:

December 1, 2012

Host: Open

NE region:

December 8, 2012

Host: Charlie McGee

Phone # 918-245-7279, cell 918-639-8779

Trade item: ladle

SC region:

December 15 2012

Host: Ricky Vardell

Trade item; something Christmassy

Phone: 580-512-8006

Meal provided

NW region:

December 22, 2012

Merry Christmas

Basic Blacksmithing Workshop

December 29, 2012 at Gerald Franklin's shop near Duncan Ok.

Projects include S-hook, leaves, a forge welded flux spoon, a hot cut and/or center punch, steak turner and more.

Cost is \$20, which covers all materials and lunch

Registration opens at NOON on DEC 10, 2012. To Register for this class, email Gerald Franklin at franklin@myrhinomail.com or call 580467-8667. Your Saltfork membership must be current to enroll.

SCABA member Richard Dyer gets opportunity to replicate pieces of Oklahoma History.

Richard Dyer was chosen by the Friends of Pawnee Bill Ranch to create replica outdoor lights for the mansion. He had fixtures that had been taken down to use as examples.

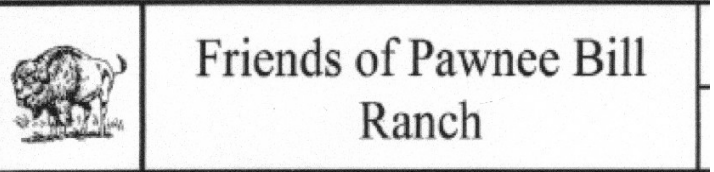
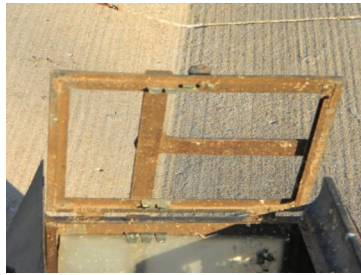
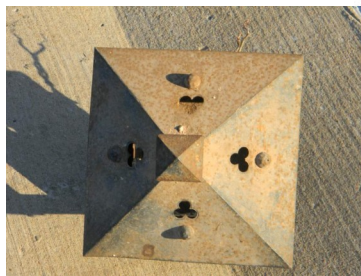

Questers Host Event for Ranch Lighting

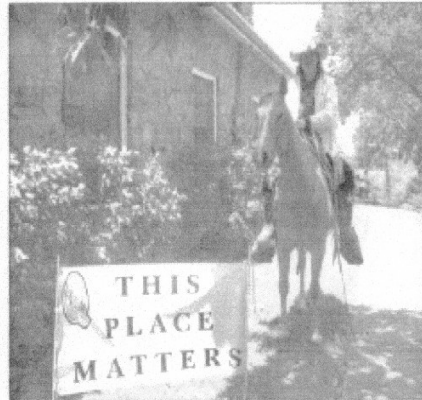

The Pawnee Bill Mansion is a little brighter now thanks to the Oil Capitol Chapter of the Questers organization. In May an event was hosted by the group to celebrate the end of the mansion lighting project which paid for the creation and installation of replica outdoor lights for the mansion front porch.

Kevin Webb as Pawnee Bill and his horse Bud

Members from Oil Capitol, T-Town, Pioneer, and Indian Nation chapters of the Questers as well as members of the Pawnee Bill Ranch Association gathered on the front lawn of the mansion to host a dedication ceremony for the end of the lighting project.

Refreshments and snacks were served before the crowd heard speeches from museum & ranch director Ronny Brown and Sharon Scott from the Oil Capitol group. At the end of the speeches, the lights were turned on for all to enjoy and a ceremonial plaque was placed at the mansion to commemorate the occasion. After the reception, members enjoyed a guided tour through the mansion. We here at the Pawnee Bill Ranch cannot thank the Questers organization enough for everything that they have done for the Ranch property. We are grateful that this organization has decided that the **Pawnee Bill Ranch is a place that matters.**

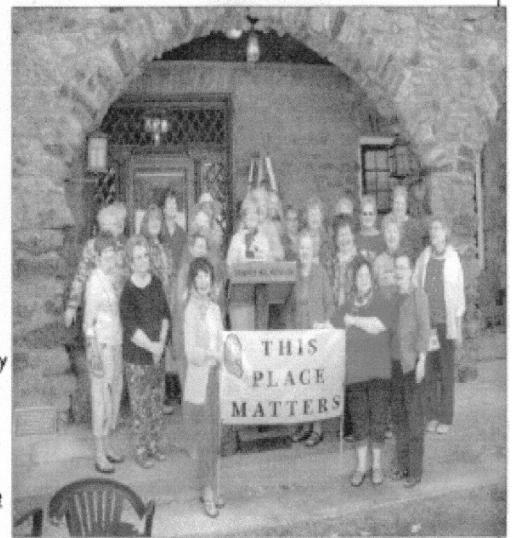

Questers gathered on the mansion front porch under the reproduction lights.

The above article announced the finalization of the lighting project. The lights were installed in May with a large reception. Check out the lighting next time you visit Pawnee Bill's Ranch.

Pictures of the finished lights are on the front cover.

Thanks to Jim Carothers for sending in these pictures and letting us know about Richards work.

Regional meeting reports:

NW...hosted by Matthew Goyer

Matthew reported that he had a small turnout of only 3 but they spent the day making Russian roses and drive in hooks. Mike Krukoski and his daughter Elora and a friend Cole enjoyed the day at the forges.

December meeting will be at Charlie McGee's place. Trade items is a ladle. Not sure about lunch.

Directions:

~~We are planning on fixing a meal and the trade item is a ladle/coat rack.~~ We are located about 12 miles north of Sand Springs. If they come through Sand Springs, they need to come out Hwy 97 N until they come to the end of Hwy 97. They will be at the entrance to Zink Ranch but they need to turn Left (W) and go about 2 miles. We are located on the Right (N) side of the road. Our house sits back off of the road and we have an electric gate that will be open. The shop is located behind the house. If anyone has any problems finding us you can give them our number. 918-245-7279.

SC...hosted by Bill Davis

Weather was perfect for a day of forging at the Davis place. There was a good turnout. Gerald Franklin set up his forge outside while the gas forge was kept busy inside making Damascus billets. Donovan Crawford and Bill worked most of the afternoon on a large billet for Donovan.

The trade items was a candle holder and there was a nice selection presented.

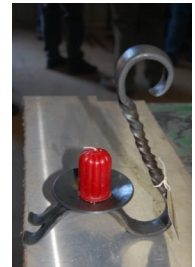

Teresa Gabrish taught a class on mixed metals. She had one student that came from Tulsa to take the class. We enjoyed a lunch of Stew and cornbread and had lots of deserts to choose from thanks to the generosity of the other members. We want to thank Ron Lehenbauer for bringing his tailgating items. We managed to get some more copper sheet from him. He also brought the nail board that he won at the conference. There are some nice nails in it. Anyone would be proud to have gotten it.



Decembers meeting will be hosted by Ricky Vardell at his shop in Temple, Ok. Ricky has chosen something Christmas-y as the trade item. He and his wife are providing a lunch but bring a side dish to help out. If you have any questions for Ricky you can contact him at 580-512-8006. See map on page 7.

Map to Ricky Vardell's home in Temple, Ok.

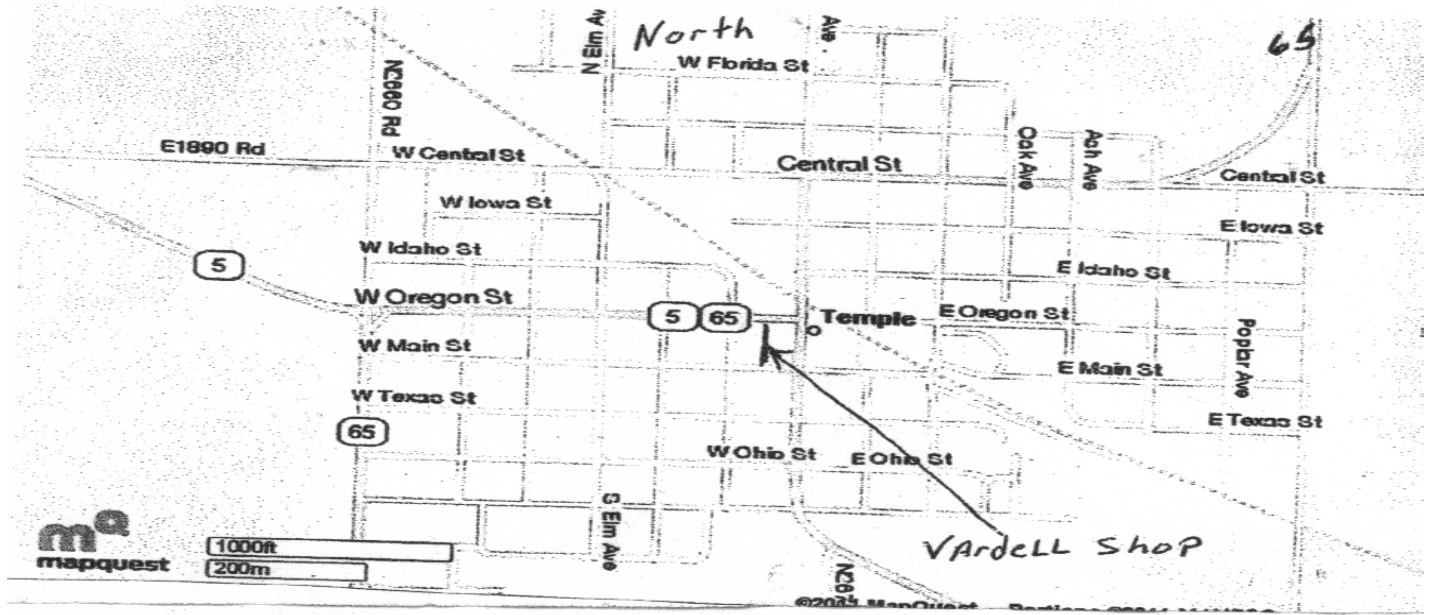

NW regional meeting hosted by Roy Bell.

Roy Bell's meeting was at Foss, Oklahoma on Nov. 24 at the home of Mandell and Laquitta Greteman. There were about 20 members present. Fun was had by all with good food and great trade items. There were some really nice bells made. Would like to thank everyone for the great food and deserts that were brought.. It was a great day. Ron Lehenbauer also brought the nail board and shared it with everyone.



2013???

What is going to happen then...

Its time for us to start our plans for the upcoming year. We have workshop to organize, meeting to find host for and events to find workers to attend. Here is where the membership needs to give us their input. Remember, **if you don't help or give us your input you can not gripe when it doesn't happen.**

Workshops..are held in months with a 5th Saturday. Those months are: March, June, August and November. We need your suggestions as to the type of workshop you want to attend and a location. (example: basic blacksmithing class at Route 66 museum blacksmith shop in March)

Here are some suggestions that I came up with:

- Basic Blacksmithing
- Dutch Oven cooking
- Photographing ironwork
- Decorative punches
- Blacksmithing "beyond basic"
- working with non-ferrous metals
- Scrolls, curls and twist
- Putting it together-rivets, collars and tenons
- How to demonstrate for the public

Other events that happen each year that you might want to get involved in are the Medieval fairs that are held in Norman, Muskogee Castle and the Scottish Rights. Saltfork has among its members some really talented Medieval Reinactors that attend these events every year. If you think that you would enjoy dressing up and pretending that you are from a "fairer" time then attend one of these events and get to know the blacksmiths. They can advise you as to how to get started.

The State Fair of Oklahoma is another event that Saltfork has demoed at for the past 3 years. Those that work in the Centennial Experience area dress up in early frontier style. The area is set up to give fair goers an idea of what life was like on the frontier. The blacksmiths spend the day forging and visiting with fairgoers answering questions and hearing stories about "My Grandfather was a blacksmith". The fair goes for 11 days and we can always use members that have some experience demonstrating for the public.

Pawnee Bills is a unique opportunity to demonstrate for the public. Jim Carothers, Tom Nelson and others spend several weekends during the summer forging in the Ranch Blacksmith shop during events that are taking place. If you haven't been to the Pawnee Bill's Ranch even to just look around you need to plan a day trip this coming year and go experience the history there.

This is just an example of events that SCABA members attend and demonstrate at each year. What we need is for you to send us your suggestions for workshops, classes or to volunteer to help out at some of the events. There are always more events needing blacksmiths that there are members willing to demonstrate. It not hard to demonstrate for the public, you just need to pick some simple items and then practice making them until you are comfortable and then just don't forget to visit with them.

Don't forget that SCABA has a scholarship program. Members can apply for help attending classes or workshops offered by other clubs or schools. You need to be a member in good standing by having your dues current, been a member for over a year and have attended some meetings. You can find an application online on our website or you can receive a copy by mail by contacting the editor or secretary. Once you attend the class you have a certain amount of time to fulfill the agreed upon reimbursements.

Classes do not have to be Blacksmith related as long as they would be of interest to other club members. Example: Jewelry making, stained glass, mosaics, quilting, tin smithing, etching of metals, knife making, cooking (we all like to eat)...you get the picture. If it is something that you can go do and then come back and teach to the rest of us then it will probably be approved. All you have to do is apply. SCABA usually helps with a percentage of the tuition and travel. So if you are thinking about a class, apply for a scholarship.

Continued on page 14.....

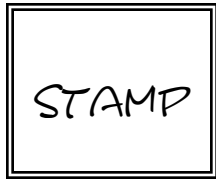

SCABA Editor
Diana Davis
23966 NE Wolf Rd
Fletcher, Oklahoma 73541

This page left blank for removal and posting.

2013 is fast approaching. We need to fill out meeting calendar.

SE Region (1st Sat)

Jan..**open**
 Feb..Eddie Horton
 March..Bill Phillips
 April.. **Open**
 May..Eddie Horton

June..**open**
 July..**open**
 Aug..Eddie Horton
 Sept. **Open**
 Oct. **Open**
 Nov. Bill Phillips
 Dec. **Open**

NE Region (2nd Sat)

Jan..**open**
 Feb..Bill Kendall
 March..Doug Redden
 April..Ed McCormach
 May..Omar Reed/Gerald
 Brostek

June..Mike Krudoski
 July..**open**
 Aug. **open**
 Sept. James Maybery
 Oct. **Open**
 Nov. **open**
 Dec. **open**

SC Region (3rd Sat)

Jan. Gerald Franklin
 Feb..**open**
 March..**open**
 April..State picnic
 May..Heather Morefield

June..Larry Mills
 July..**open**
 Aug..**open**
 Sept. **Open**
 Oct. SCABA Conference
 Nov. **open**
 Dec. **open**

NW Region (4th Sat)

Jan..**open**
 Feb..**open**
 March..Bob Rea
 April.. **Open**
 May..**open**

June..**open**
 July..**open**
 Aug. **Open**
 Sept. **Open**
 Oct. **Open**
 Nov. **open**
 Dec. **open**

Saltfork Craftsman Regional Meeting Hosting Form

Region _____ SE _____ NE _____ S/C _____ NW

Date: Month _____ day _____ [correct Saturday for region selected above]

Name _____

Address _____

Phone/email _____

Trade item _____

Lunch provided _____ yes _____ no

Directions or provide a map to the meeting location along with this form.

****All meeting are scheduled on a first come basis. Completely filled out form MUST be received by editor no later than the 23rd of the month TWO months PRIOR to the meeting month.**

Completed forms can be mailed or emailed.

You will receive a conformation by email or postcard.

A form must be filled out for each meeting.

SCABA membership application

New _____ Renewal _____

April 1 2012—March 31— 2013_

Please accept my application

Date: _____

First Name _____ Last Name _____

Married? ___ Yes ___ No Spouses Name _____

Address _____

City _____ State _____ ZIP _____

Home Phone (____) _____ Work Phone (____) _____

E-Mail _____ ABANA Member? ___ Yes ___ No

I have enclosed \$20.00 (per year) for dues to March 30, 2013_

Signed _____

Return to: Saltfork Craftsmen Membership, Diana Davis 23966 NE Wolf Rd. Fletcher, Okla. 73541

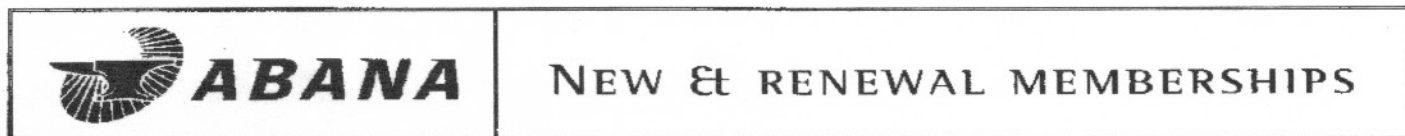

Name : _____ Membership ID # _____
(For renewals. Optional but very helpful)

Business Name (optional) : _____

Street : _____

City : _____ State/Prov : _____

Zip/PC : _____ Country : _____

Phone : _____ Fax : _____

E-mail : _____ Website : _____

Membership Type: New Renewal

Regular (US, Mexico, Canada)	One Year — <input type="checkbox"/> \$55	Two Years — <input type="checkbox"/> \$105
Senior Membership (65+, US, Mexico, Canada,)	One Year — <input type="checkbox"/> \$50	Two Years — <input type="checkbox"/> \$95
Full-time Student (US, Mexico, Canada)	One Year — <input type="checkbox"/> \$45	Two Years — <input type="checkbox"/> \$85
Foreign	One Year — <input type="checkbox"/> \$65	Two Years — <input type="checkbox"/> \$125
Contributory Membership <i>(amounts above \$55 / year may be tax deductible)</i>	One Year — <input type="checkbox"/> \$150 and up — \$ _____	Two Years — <input type="checkbox"/> \$295 and up — \$ _____
Public Library (US, Mexico, Canada)	One Year — <input type="checkbox"/> \$45	
Educational Institution	One Year — <input type="checkbox"/> \$250	

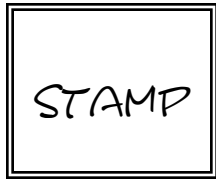

SCABA Editor
Diana Davis
23966 NE Wolf Rd
Fletcher, Oklahoma 73541

This page left blank for removal and posting.

Saltfork Craftsmen ABA member Levi makes pretty good tongs; I'm fortunate to have a pair or two he made for me. Several years ago Levi showed me a tip to take about half the slack out of the tongs riveted joint. A small chisel or an old star drill (hand concrete drill) is used to cut small notches at the outside of a hole in the joint. It is best to make these cuts on the side of the tongs that will have the rivet headed. These notches prevent the headed rivet from rotating in that side of the tool. Notching other single riveted joints, such as the legs connected to a campfire cooking trivet, works nearly as well as a square rivet in preventing unwanted rotation. For the trivet legs, chisel cut both the ring and the legs; heat and forge both ends of the rivet.

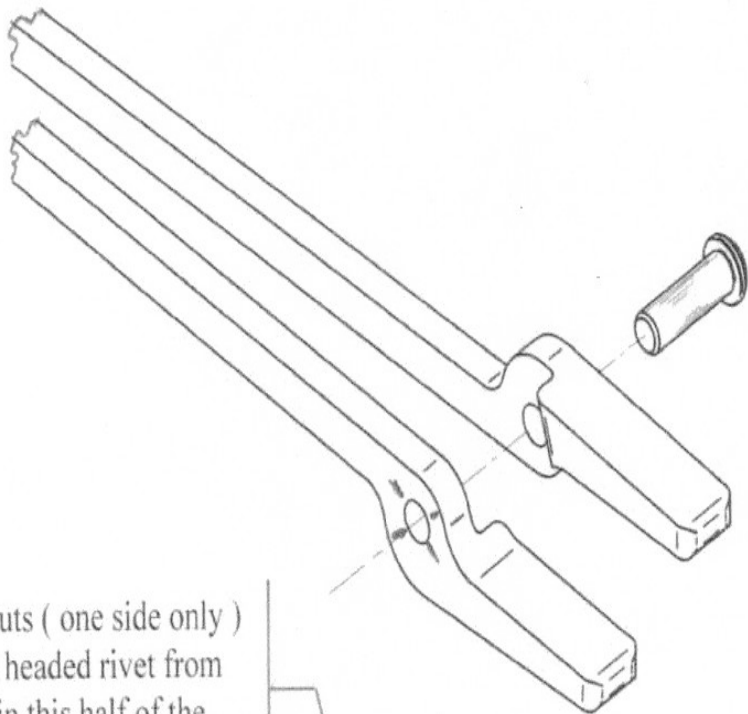
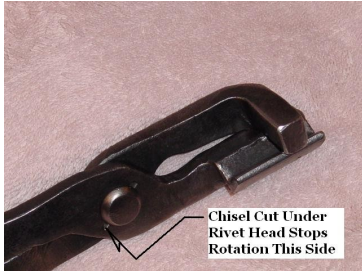

Chisel cuts (one side only) lock the headed rivet from turning in this half of the joint.

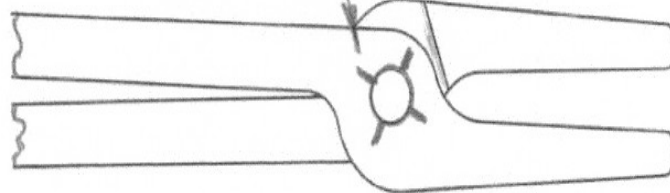

Jim Carothers Frontier Shop Perry, OK 08-21-2012

Field trip to Paris Texas.

In Mid November a group of 17 from Kaufman Texas stopped by my shop in Paris Tx. for a tour and a brief demo. The trip was coordinated thru the Chamber of Commerce and they came to Paris solely to visit my shop. They were a great group and asked many questions. The men were especially interested in a power hammer demo and all were wanting to see the coal forge in action.

James Allcorn



Your club continued...

The annual picnic is coming in April and Byron Doner is organizing it. We have the fair grounds in Norman booked for the day. If you want to help with the planning or have a suggestion as to some contest or workshop that would be enjoyed by the membership,...call one of your board of directors and volunteer to help or just make the suggestion. We can't guarantee it will take place but we won't know about it until you suggest it.

SCABA has been organizing an annual conference for so long that you would think we knew what we were doing but we always can use new ideal and workers. Some of the original organizers are still doing the same jobs that they did when we started. This is fine, nothing can beat experience but you have to remember, that person doing a job to make the conference better for you is not always getting to enjoy the conference in the same way your are. They may be stuck behind a registrations desk or running around trying to make sure everyone has fresh coffee when they come out for a break. We ask for comments at the end of each conference to see where we can make changes. Some of the things are beyond our control but we do try to fix the things that are within reason. Like the smoke accumulation in the building. Sometimes we get comments about minor things like coffee making or raffle ticket sales but no where on the bottom of the sheet is the words "I volunteer to help with this next year" This is where we need members to step forward and start giving back to the club. I have set on those bleachers and I know from experience that sometimes you need to get up and walk around to get things working again. This is the time when you go out and make that fresh pot of coffee or get some of those raffle tickets or iron-n -hat tickets and walk around and try to sell them. The club doesn't ask for more money than your yearly dues but what we do need is some of your time. We need members to volunteer to give back to the club with their time and energy to help with the projects and events that the club host or sponsors. We need members to help by serving on the board. Volunteering to host meetings. Helping with conference activities. This is your club, Help us make it the best club possible. Get involved.

2013..what kind of year can **We** make it?

Diana Davis/ editor

Teaching Blacksmithing...

Gerald Brostek and other SCABA members have been busy teaching another group of women. This time they assisted the NWTF, Women in the Outdoors program that was held at Tenkiller State Park by teaching a basic blacksmithing class to their group of women. The basic blacksmithing class was held on November 3rd and 4th and was attended by 23 students. Each student made a drive hook using their newly acquired skills taught by SCABA members James Mayberry, Dallas and Gerald Brostek.



Member showcase:

Jim Carothers sent in these pictures of some wall hooks he saw while visiting with fellow SCABA member Tom Nelson at his home and shop near Douglas Oklahoma recently. Tom brought some similar hooks to the conference this fall.



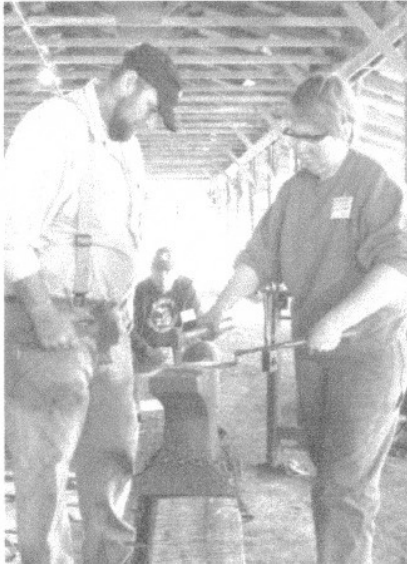

Tips From A Friendly Fire

This year at SOFA, one of the premiere demonstrators was Susan Hutchinson. PAABA members were very pleased to see her since she demonstrated at John Steel's Shop in 2011! Susan shared the following tips during her demonstration.

-Using the horn on the diagonal can give you a true radius, think about it and give it a try!

-All parts of the anvil is a tool, think of the base as a swage block.

-If you are pretty good at something, offer to demonstrate. You will practice in order to get better, use the commitment as an incentive.

-It does not take a lot of skill to put texture on a bar, but it adds a lot of interest to your work and kicks it up a level.

-Don't get more tools than you need, use the tools you have! (No excuses!)

-Every year a new "tool" becomes fashionable, think it through before you purchase a big tool. (For Susan, her treadle hammer became an elaborate center punch!)

-Be careful of points on a finished project for sale, it can become a liability for the customer.

-Work backwards from the point when making a long taper.

-Customers look at the fine detail when work is installed, make sure your taper points are well crafted.

-Use clay with a hammer to figure how/what you need to do for a project.

-When using a power hammer, correct a problem before it goes way wrong!!!

-Often the tools you started smithing with are the tools you will gravitate toward as you perfect your skills.

-Pretty rat tail tapers are done on a radius die (gentle radius), the aggressive radius die are better for texture.

-When demonstrating, you can fake your way through a burn, but you cannot fake it through blood. If the project you are demonstrating has pointy tips, address the tips soon after making them by scrolling or finishing them.

-Just because it is traditional (collar), does not necessary mean it is good for the design.

-Making rivets-Use a ball swage then draw out behind it. Then use a another swage die to draw a stem out from the ball. Easy, and effective!

-If you are using a swage die, be careful if you are using a radius die in your hammer, it can kick out!

-A rivet does not have to be round, you can make them, in a variety of shapes, triangle, diamond, eyebrow triangle, or even scroll them!



- Sculpt Nouveau has a newer product called, Black Metal Oil. It can go on warm or cold, covers file marks, grinding marks, and you can layer it. You can also apply a top clear coat. Apply, then wipe off!

For our "Feathered Fiends", this project just might be the ticket to a great Thanksgiving Turkey! Thanks to the Ocmulgee Blacksmith Guild and The Florida Clinker Breaker ('96) for this project!

ROASTING SPIT

By: David Fink of Lumpkin, Ga.

Material Needed: 1/2" x 1/2" x 24" - 2 pieces
 1/8" x 1/2" x 7" - 2 pieces
 1/8" x 1/2" x 10" - 2 pieces
 1/8" x 1/2" x 5" - 2 pieces
 3/8" x 3/8" x 28" - 1 piece

1- Stack the 1/8 x 7 on the 1/8 x 10 and secure with wire while welding. Taper the welded area as shown in figure 1. Repeat with other like pieces.

2- Weld the above parts to the top of each of the 1/2 x 24" pieces as shown in figure 2.

3- Forge a point on the other end of the 1/2 x 24.

4- Heat the welded end and pull the 7" piece up and forge into a "U" shape. Reheat and repeat the operation on the 10" piece to form an object similar to that in figure 4.

5- Upset one end of the 3/8" bar to about 1/2" square and flatten. Over the edge of the anvil, forge this flattened section into a round one and punch a hole in it's center of a little over 5/16" diameter. Forge the 3" under this eye into a rounded cross section as shown in 5a and b.

6- Forge the opposite end of the 3/8" bar to a tapered point and forge the 3" behind that point to a rounded cross section similar to the other end as shown in figure 6.

7- Forge both of the 1/8 x 1/2 x 5" pieces to a long sharp tapered point on both ends. Measure the resulting pieces and mark the center point. Punch a 1/4" square hole in the center of each piece then drift to 3/8" square.

8- Slip these onto the 3/8 square bar (made in steps 5 and 6 above) and heat each of them in turn.

9- Use a scrap piece of 1/2" thick material as a spacer to form the last parts into a squared "U" shape as shown in figure 9.

10- Optional. A 20" x 1/4" round rod can be pointed on one end to hold cross bar in position.

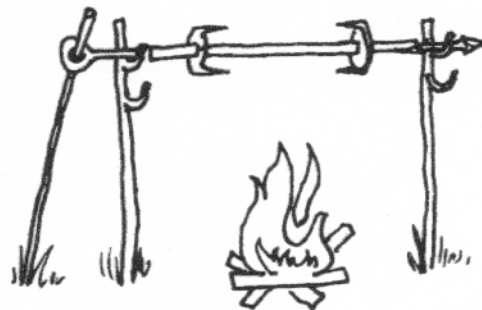
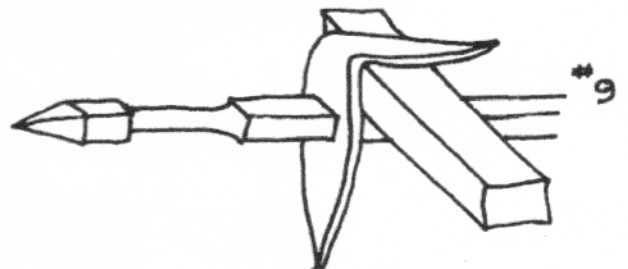
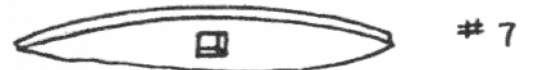
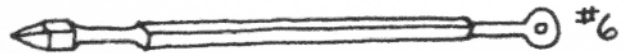
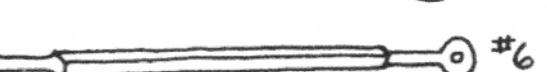
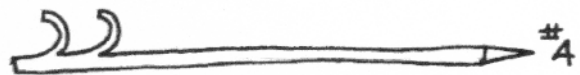
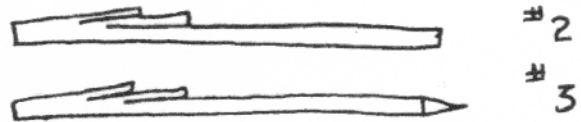

SCABA Shop and Swap

For Sale:

6" round nosed pliers (great for putting scrolls on small items) \$5.00 each. Brooms tied, \$25.00 on your handle
Contact Diana Davis at Diana.copperrose@gmail.com

For Sale:

24"(wide) x 1"(thick) Ceramic fiber blanket (similar to Kao-wool) \$1.00 per inch of length. Twisted solid cable 1/2" diameter \$2.00 per ft.
Contact Larry Roderick at 940-237-2814

Wanted:

Advertising Coal Hammers, Contact Mike George at 1-580-327-5235 or o Mike-Marideth@sbglobal.net

Club Coal

Saltfork Craftsmen has coal for sale. Coal is in 1-2" size pieces The coal is \$140.00/ton or .07 /pound to members **No sales to non-members.**

NW Region coal pile is located in Douglas, OK. If you make arrangements well in advance, Tom Nelson can load your truck or trailer with his skid steer loader for a fee of \$10 to be paid directly to Tom. Tom has moved his skid steer and must now haul the loader to the coal pile to load you out, hence the \$10 charge. You may opt to load your own coal without using Tom's loader. The coal can be weighed out at the Douglas Coop Elevator scales. Contact Tom Nelson (580-862-7691) to make arrangements to pick up a load. Do not call Tom after 9 PM!! Bring your own containers and shovels. Payment for the coal (\$.07 per pound) should be made directly to the Saltfork Treasurer.

NE Region coal location: Charlie McGee has coal to sell. He lives in the Skiatook, Oklahoma area. His contact information is:
littleironworks@gmail.com or (home) 918-245-7279 or (cell) 918-639-8779

Show your pride in SCABA. License plates for \$5.00 each. We have coffee cups for \$9.00 with two images on them and We just got in a new shipment of caps for \$10.00. Dan Cowart has the cups and caps available in the NE region and will be available at the picnic in April.



SCABA swage blocks

\$100.00 plus shipping to members. (1st block)
\$120.00 plus shipping to non-members
Contact Bill Kendall for more information



SCABA Floor Cones are now available from Bill Kendall, Byron Donor and Gerald Franklin. The price is \$200 plus shipping and handling.



For Sale:

SCABA insulated travel mugs. Orange and white with Saltfork Logo . \$10.00 each Contact Diana Davis for more info. Will be available at most SC meeting and at the picnic in April.

For Sale:

Larry Mills has a nice selections of Klingspor Abrasives for sale at this shop in Norman. If you needs more information or to purchase contact Larry at 405-401-9739 or email at l-lmills@cox.net

Saltfork Craftsmen Artist Blacksmith Assoc.Inc.
10380 N. 4010 Road
Wann, Okla.74083

U S Postage Paid
Non Profit Organization
Permit #8
Sterling Ok.
73567

Address Service Requested

