

Saltfork Craftsmen Artist-Blacksmith Association

April 2013



Another nice Bell hanging from a tree limb made by Ed McCormack. Ed also has a bell that placed 1st at the ABANA conference. You can see it in the most recent Anvil Ring.

Saltfork Craftsmen
Artist-Blacksmith Association
Officers and Directors

President: Gerald Brostek 918-687-1927
205 N. Anthony
Muskogee, Ok. 74402
Gerald.brostek@sbcglobal.net

Vice-President/events: 580-688-3555
David Seigrist
P.O. Box 163 Hollis, Ok 73550
dseigrist2004@yahoo.com

Sec-Treas. Dan Cowart 918-440-0653
10380 N. 4010 Road
Wann, Ok 74083
ddcowart@gmail.com

Director/Editor: Diana Davis 580-549-6824
23966 NE Wolf Rd.
Fletcher, Ok 73541
Diana.copperrose@gmail.com

Director/cones: Byron Donor 405-650-7520
6520 Alameda, Norman Okla.
byrondoner@earthlink.net

Director/swage blocks: Bill Kendall 918-742-7836
1756 E. 59th St Tulsa Ok. 74105
wwkendall@aol.com

Director: Mark Carter 405-964-5754
34509 Hazel Dell Rd.
McLoud Ok.74851
mcarteriron@gmail.com

Assignments:

Webmaster:
Dodie O'Bryan
Pawnee, Ok
scout@skally.net

Workshop Coordinator:
Tracy Cowart 918-376-2382
9911 N. 117th E. Ave.
Owasso. Ok
draftsman@cox.net

The Saltfork Craftsmen Artist-Blacksmith Association, a non-profit organization of amateur and professional artist and craftsmen, publishes this newsletter monthly. Our purposes are the sharing of knowledge, education and to promote a more general appreciation of the fine craftsmanship everywhere. We are a chapter of the Artist-Blacksmith Association of North America.

Material from this newsletter may be freely copied without permission for non-profit purposes. Please credit the author and this publication.

Visit our Saltfork Craftsmen Website:
www.saltforkcraftsmen.org

Editors ramblings....

I been receiving a lot of membership application in the mail the last few weeks and I want to thank everyone that took the time to fill one out instead of just sticking a check in the mail. You would be surprised at the tiny mistakes that have been found by checking over the information that you provide. How many of you changed your email address this past year. There have been several of you. And also telephone numbers or even the spelling of the street names. With the post office going through so many changes they have become very particular about things and will refuse to deliver an item for the slightest of mistakes and that is why I have requested that you fill out my silly form. It cost the club every time a newsletter is returned and it would be terrible for us to have to go up on memberships to cover these cost. Help us keep down postal cost by letting us know whenever you move or change anything that will effect the delivery of your newsletter.

Everyone needs to look at the label on their newsletter. If it has a M-13 you need to get me your dues ASAP. This is the last newsletter you will receive unless I receive your dues by May 26th.

April is a busy month for us. We have board of directors elections. There is a ballot in this newsletter. Please remove it and mark your choice of four members to set on the board. If you have a candidate that will run, write him or her name on the ballot. Vote for four either way.

The picnic will be held on the third Saturday in April at the home of Byron Doner. The club provides the meat for this event so we need those attending to bring side dishes to go along with it. You will find an article by Carol Doner concerning food on page 7.

Editor.....



From the Prez...

Spring has arrived and the Easter flowers are blooming. It is also the start of Tornado season, so be careful out there. One of the great experiences of spring is the Saltfork Craftsmen's annual spring picnic. This is fun filled event where those who show up get to visit with folks from the far reaches of our membership area, eat more than they should, and find out who the new Board members are.

We will again have a nail making contest. The rules are quite simple, make three nails from 1/4" square stock in an allotted time. We will round up a few non-participating Ladies and have them judge the nails based on uniformity. Diana has a couple great prizes for the winners so practice up and bring your favorite hammer and nail header or use one of ours.

This is a great opportunity to sell or trade any blacksmithing tools, forges, anvils etc. that you may have too many of, or to trade them for something you need or want. I know there are several "new to the craft" folks looking for anvils and forges.

If you made something lately that you are proud of bring it along to "show". We all enjoy looking at other blacksmiths work.

"God Bless our Craftsmen and Craftswomen"



Don Bellah Memorial Scholarship

The Saltfork Scholarships/Grants Program and Application:

Since founding in March of 1995, the Saltfork Craftsmen ABA has been committed to high quality educational opportunities for our members and our region. The purpose of the Don Bellah Memorial/Saltfork Craftsmen ABA Scholarship/Grants Program is to provide Club Members with financial assistance toward that end.

1. The Scholarship/Grants Program will provide funding each year to aid in increasing skills and abilities through participation in schools, conferences, or special classes. The total amount of funding and the distribution limit per person/application will be set annually at the First Board/Trustees Meeting. Unused monies will be rolled over for use the following year. **Scholarship Grants will be funded at 50% of eligible costs not to exceed \$1000.00 per Member for the 2013/2014 year.**

Because the Saltfork Craftsmen ABA desires to promote and sustain an interest in blacksmithing and other crafts, funding is available to interested blacksmiths, blacksmith educators, other craftsmen, and other craft educators at all skill levels – novice to journeyman.

Requirements for Selection of Scholarship/Grant Funding:

2. The applicant must be an active member of the Saltfork Craftsmen ABA for at least one year 12 consecutive calendar months. The applicant must have attended at least 4 general or area Saltfork meetings in the past 12 months.
3. The applicant must have applied for conference, school, or class that must be deemed to also be of benefit to other members of the Saltfork Craftsmen ABA by the Scholarship/Grant Committee.; The school, class, or conference is not limited to just blacksmithing.
4. Applications will be reviewed by the Scholarship Committee as they are received, sent to Gerald Brostek. Results of this review will be reported to the Board of Directors By Gerald Brostek.
5. Should there be more applications than there is money available in the Scholarship/Grant fund, applicants will be selected by drawing of names and the funds divided by the Scholarship/Grant Committee.
6. Recipients of previous Scholarship or Grant awards are not eligible to submit another application for two years after the completion of the conference, school, or class and fulfillment of the Applicants Responsibilities listed below.

Applicant's Responsibilities for Selection of Funding:

- As a condition of receiving Saltfork Craftsmen ABA Scholarship / Grant funding, all recipients are required to share the results of their learning with other Saltfork members.
- The recipient is further encouraged to share this learning with other ABANA Chapters and / or ABANA proper.
- The recipient will fulfill this responsibility by at least two of the following forms of presentation:
 1. A public demonstration, lecture, or organized workshop at a General Meeting of the Saltfork Craftsmen ABA covering what was learned in the class or conference.
 2. The submission of an article for the Saltfork Newsletter and / or ABANA or other artist-blacksmith association newsletter or related publication.
 3. Making and donating an item for the Annual Conference "iron in the hat" or other Saltfork Auction. The item should be from the class or conference. Money received from this item, if auctioned, will be added to the Scholarship/Grant Program account.

The fulfillment of the Applicant's Responsibilities, as listed above, must be completed within 12 calendar months after the course of study is completed. The Saltfork Craftsmen ABA Scholarships/Grants Committee will have the final say as to whether the requirements are deemed as being met.

Minutes
Saltfork Craftsmen Artist Blacksmith Association
2/9/13 at 1:00 pm.
Tulsa, OK
Bill Kendall's shop at the North East SCABA meeting
5245 South Peoria
Tulsa, OK 74105

Members Present: Gerald Brostek, David Seigrist, Danny Cowart, Byron Doner, Bill Kendall, and Diana Davis.

Members Absent: Mark Carter.

Minutes of 10/20/12: Copies were handed out and reviewed. The picnic was changed from the fairgrounds to Byron Doner's home. David made a motion to accept and Byron seconded and all approved.

Don Bellah Memorial Scholarship: Two handouts: 1 was the Don Bellah internet form and the others were the changes made 8/11/2012.

See Attachment for details of change. Attachments in red. If approved this will be sent to Dodie along with a request that we make the form interactive with the members.

The swage block patterns have been retrieved from Oil City Foundry and taken to Empire Castings in Tulsa. The board approved the quote and also approved having Empire Castings to make three swage blocks for approval. If approved they will cast 100 total swage blocks. See attachments.

Dan Cowart handed out the results of the 2012 Perry, OK Conference.

Dan Cowart made a motion to look for SCABA insurance in Bartlesville, OK and it was seconded by David Seigrist. The BOD will approve the results of whether or not to change from Brook's Insurance Alva, OK to one in Bartlesville, OK.

Gerald Brostek agreed to finish up the vacant Scholarship Committee Member position made vacant by Don Garner.

Tracy Cowart agreed to take Gerald Franklin's place as Workshop Coordinator. Tracy's main job as Workshop Coordinator will be to set up workshops on the fifth Saturdays in each month. On those Saturdays we will try and have training in Basic Blacksmithing, tool making and other classes that members might want. When we have a class the coordinator will notify Diana and Dodie to get it advertised and the forms sent to Dan Cowart for reimbursement.

Tracy Cowart reported on the video progress from the 2012 Perry Conference: Bob Patrick will be ready at the picnic this year. The Lucian Avery may be also ready. Both will be on two DVDs.

April's meetings...

- ◆ NE Regional meeting will be hosted by Ed McCormack on April 13th. at 15100 N. 270 Rd. Okmulgee Okla. Contact info. 1-918-733-9844. trade item is anything made from a RR spike. Lunch provided bring a side dish to help out.
- ◆ SC Regional will be hosting the picnic at the home of Byron Doner on April 20th. Lunch is provided by the club but side dishes and deserts are encouraged. Come and bring your lawn chair, horse shoes game etc and enjoy the day. There will be a nail making contest for anyone that wants to give it a try.
- ◆ NW Regional meeting will be hosted by Don Garner at Thomas Ok. Contact info. 1-580-302-1845 (cell) or home 1-580-661-2607. trade item is a forge tool. Lunch is provided but bring a side dish to help out.

Directions: highway 33 west side of Thomas 2 north 3/4 west on county road 860. white house on north side of road.

Picnic update...by Carol Doner

Menu for Spring Picnic

Hamburgers & Hotdogs

Shirley Mantooth is bring deviled eggs

Diana Davis is bring baked beans and a case of diet cokes.

Please contact Carol to coordinate side dishes, text or phone: 405-760-8388 or email at carol-doner@hotmail.com or call 405-329-5635 (home)

Anyone wanting to bring their signature cabinet door knob or drawer pull for a housewarming gift. Bring it on, feel free to park anywhere. And don't forget a chair..

The Picnic is being held at Byron and Carol Doner's home at 6520 Alameda in Norman Oklahoma. If coming from the South, take the Tecumseh exit off I-35 and go to 60th street. Turn (L) north to Alameda. Turn (R) east and go a little over 1 block. House on (R) side of road. Sail boat in yard.

From North take I-35 S to exit 113 merge unto US77, turn (L) unto W Tecumseh road, turn (r) on 24th ave go 3 miles and then (L) onto Alameda, go east 3.6 miles to 6520 on (R).

May meetings...

- ◇ SE Regional meeting will be hosted by Eddie Horton at Fort Towson Historic site on May 4th. Eddie can be contacted at eddie.h3@gmail.com The trade item is a "critter cooker" Lunch is provided but help out with a side dish or desert. Mr. Wallace will be cooking in the Dutch ovens again so go by and get some pointers on how its done.
- ◇ NE regional meeting is being hosted by Omar Reed and Gerald Brostek on May 11 at the Fort Gibson Historic site. Omar can be contacted at 918-478-4088 and Gerald has an email address of...Gerald.brostek@sbcglobal.net The trade item is anything used in "Campfire Cooking". Lunch is provided but bring a side dish or desert to help out. There is no burn ban so bring your portable forges and set up under the trees. Gerald will be demonstrating how to make a cooking tri-pod.
- ◇ SC regional meeting will be hosted by Heather Morefield at the blacksmith shop in Medicine park located on east side of water treatment plant on May 18th. Lunch will be provided but bring a side dish to help out. The trade item is a piece of "Yard Art"
- ◇ NW regional meeting will be hosted by Gary Seigrist at the Rout 66 Blacksmith Shop in Elk City (2717 W. 3rd) on May 25th. Gary can be contacted at 1-580-243-8228 Lunch is provided but bring a side dish to help out. The trade item is anything made from a horseshoe.

Elk City museum complex is located on west side of Elk City on 3rd Street.

TIME AGAIN FOR THE



Annual Southwestern Ironworks Tailgate Swap Meet

**AND
MODEL ENGINE DISPLAYS**

**SATURDAY MAY 18, 2013
8:00 AM TILL.....**

**ALL HOBBY MACHINISTS, BLACKSMITHS
AND WOODWORKERS
BRING YOUR UNWANTED
TOOLS OR EQUIPMENT
AND BUY -- SELL -- TRADE**

**302 WEST COLLEGE
Guthrie, Okla.**

**FOR MORE INFORMATION CONTACT:
DAVID KING, (405)348-0476 OR BOB PADDACK, (405)634-8353, (405)642-5243
(405) 426-0476**

BAM

22nd Annual

Ozark Conference

May 2nd - May 5th, 2013

**Missouri State Fairgrounds
Sedalia, MO**

*Pre-Registration must be postmarked by
April 5th, 2013*



**CHEROKEE STRIP MUSEUM
2617 WEST FIR - PERRY, OKLAHOMA
580-336-2405**

RURAL HERITAGE FESTIVAL

SATURDAY, APRIL 27, 2013

10:00 AM to 3:00 PM



BRING YOUR FAMILY AND ENJOY THE FUN!

- ◆ WRAPPING OF THE MAY POLE - 11:00 & 12:00
- ◆ 1910 ROSE HILL SCHOOL SESSION - 11:15
- ◆ GREAT PLAINS DULCIMER ALLIANCE- 12:30
- ◆ SALTFORK BLACKSMITHS
- ◆ COWBOY CAMP
- ◆ SETTLER'S CAMP
- ◆ ROPE MAKING
- ◆ NOBLE CO. ANTIQUE TRACTOR ASSOC.
- ◆ CAKEWALKS-10-12:30
- ◆ WEAVING/SPINNING
- ◆ QUILTING
- ◆ LACE GUILD OF OK
- ◆ LYE SOAP MAKING
- ◆ SQUARE DANCING
- ◆ FLINT KNAPPING

DONATIONS ACCEPTED

Visitors are welcome Friday evening
Also visit downtown Perry's "Spring Fest"

Upcoming events to keep in mind...

- ◆ Medieval fair in Norman April 5-7 2013
- ◆ Chisholm Trail Festival in Yukon, Ok on June 1st.
- ◆ Annabell's Fun Farm in Welch Okla. Owned by Tim Wright is looking for anyone interested in setting up on a weekend during their fall activities. If you are interested in participating in this fall pumpkin patch/corn maze and other family friendly activities beginning September 21 through November 3rd. Fridays Saturdays and Sundays you can view their website at www.annabellesfunfarm.com

-----fold-----
Dan Cowart
10380 N. 4010 Rd.
Wann, Ok 74083

Stamp

Saltfork Craftsmen 2013 Ballot

Dan Cowart
10380 N. 4010 Rd.
Wann, OK 74083-2014

-----fold-----

Vote for 4 trustees

Saltfork Craftsmen

Artists - Blacksmiths Association, Inc.
Board of Trustees Election March 2013

There are four Trustee terms expiring this year. The four trustees who's terms are expiring are:
Gerald Brostek, Byron Doner , and Bill Kendall and Mark Carter.
Gerald Brostek is not running again.

You may choose from the candidate list or you may write in any other persons who are members in good standing. Please vote for only four candidates by putting a check mark on the line next to their names.

- | | | |
|-----------------|------------|-------|
| Mark Carter | McLoud, OK | _____ |
| Bill Kendall | Tulsa, OK | _____ |
| Byron Doner | Norman, Ok | _____ |
| Chuck Waite | Tulsa, OK | _____ |
| Mandel Gretaman | Foss, OK | _____ |
| Other : _____ | | |

These candidates are all good people. Any of them will be an asset to the Club and to the Board of Trustees. Please vote only once per membership. The election dead line is April 10, 2013. Please fill in your ballot as soon as possible and mail to:

Saltfork Craftsmen 2013 Ballot Dan Cowart
10380 N. 4010 Rd.
Wann, OK 74083-2014

SCABA membership application

New _____ Renewal _____

January 2013—March 31— 2014_

Please accept my application

Date: _____

First Name _____ Last Name _____

Married? ___ Yes ___ No Spouses Name _____

Address _____

City _____ State _____ ZIP _____

Home Phone (____) _____ Work Phone (____) _____

E-Mail _____ ABANA Member? ___ Yes ___ No

I have enclosed \$20.00 (per year) for dues to March 30, 201_

Signed _____

Return to: Saltfork Craftsmen Membership, Diana Davis 23966 NE Wolf Rd. Fletcher, Okla. 73541

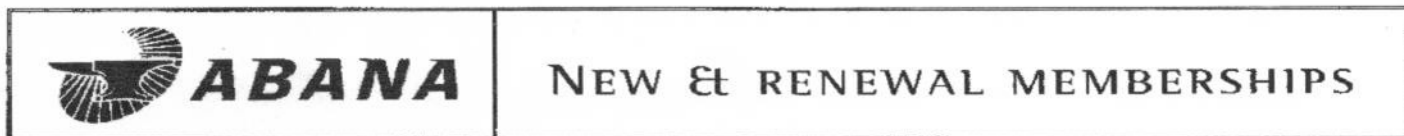

Name : _____ Membership ID # _____
(For renewals. Optional but very helpful)

Business Name (optional) : _____

Street : _____

City : _____ State/Prov : _____

Zip/PC : _____ Country : _____

Phone : _____ Fax : _____

E-mail : _____ Website : _____

Membership Type: New Renewal

Regular (US, Mexico, Canada)	One Year – <input type="checkbox"/> \$55	Two Years – <input type="checkbox"/> \$105
Senior Membership (65+, US, Mexico, Canada,)	One Year – <input type="checkbox"/> \$50	Two Years – <input type="checkbox"/> \$95
Full-time Student (US, Mexico, Canada)	One Year – <input type="checkbox"/> \$45	Two Years – <input type="checkbox"/> \$85
Foreign	One Year – <input type="checkbox"/> \$65	Two Years – <input type="checkbox"/> \$125
Contributory Membership <i>(amounts above \$55 / year may be tax deductible)</i>	One Year – <input type="checkbox"/> \$150 and up – \$_____	Two Years – <input type="checkbox"/> \$295 and up – \$_____
Public Library (US, Mexico, Canada)	One Year – <input type="checkbox"/> \$45	
Educational Institution	One Year – <input type="checkbox"/> \$250	

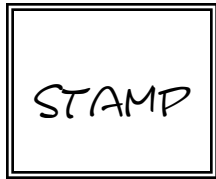

SCABA Editor
Diana Davis
23966 NE Wolf Rd
Fletcher, Oklahoma 73541

This page left blank for removal and posting.

SE Regional meeting by Jim Stubbs

Our day started around 5:30 am. I had loaded up all my hammers and tongs the night before to be ready to leave. Dawnavan showed up, we loaded up the tools and headed out. We had about a 2.5 hr drive ahead of us, at least according to the GPS. Well things went well until the GPS took us south of Bill's place. We eventually found our way to Bill's place and things were a ringing. We walked into the shop and there to our left was a large metal table with a very nicely done bell hanging from a tree limb. (see front cover) I walked over to it and snapped a picture of it. Come to find out it was made by Ed McCormack and was made from welding rod. Even the tree limb. Very nice piece Ed.

There were a few guys at the coal forge banging away and so we walked over and Dawnavan noticed what might be a piece of wrought iron one of the guys was working on. So of course we had to ask to look at it and sure enough it was wrought iron. The piece kept splitting on him and so we told him that he was not working it at the right temp. So we then proceed to help guide him on working the piece. He was able to make a nice little steak fork from the piece. Unfortunately I didn't think to get a picture. So we continued to help some of the new guys who had been showing up to Bill's place to learn. At times there were 2 and 3 guys sharing either the coal forge or the propane forge. There was some serious forging going on though. At times it was a little crowded but everything worked out fine.

Gerald Franklin had showed up and of course he joined right in with helping teach some of the new guys also. One of the guys asked Gerald about doing a bottle opener and Gerald wrote the steps down for him and then helped him to make his own little bottle opener.

The trade item was a punch and a few of the new guys were able to get one made before the end of the day. A few started to make them but had to leave before they were able to finish it. Hopefully next time they show up they will be able to finish them. I believe a few might have been made for the tool box but am not sure. I believe there were about 5-6 trade items made or brought for the trade item swap.

Lunch was served and if anyone went away hungry then it was their own fault. There was corn chips and Johnny cakes and some home-made chili-mac and of course there was also the cheese and onions to go with it. Desert were good also. The cherry cheesecake was pretty dang good, I can tell you that.

After lunch there was a little less forging going on but there were a few. Byron brought some coal in a little 5 gallon bucket that he wanted to try out and so Bill threw some into the coal forge and proceeded to make a small little bottle opener. Where ever Bryon got the coal from it was some nice coal. Hmmm, I might have to sneak over to his house and see if I can find that bucket. LOL

So as the afternoon was getting longer those that had long rides home started packing up and heading home. I believe Dawnavan and I were the last ones to leave Bill's place but not before we had a chance to load up a couple drums of coal from Bill's little pile. Plus a few pieces of some nice Bois d'ark wood. The truck was a little heavier then when we first arrived early that morning. Hopefully we were able to show the new guys some things and they were able to learn something new. Overall it was a great day and a great time at Bill's Phillips.



SC regional meeting

Bob McKelvin and Shirley Mantooth hosted the meeting for the SC region at their home east of Rush Springs Okla. You couldn't have asked for a better Spring day to be outside forging. Bob had his inside forge going and there were a couple of forges going outside.

He had a good turnout with about 20+ members coming and going during the day. The trade item was a bell and he had a few show up.



Teresa Gabrish came with her jewelry and was showing the results of an etching experiment that turned out some interesting textures on her copper. She has been asked to do a demo on the technique at the conference this year.



A lot of those that came enjoyed visiting with others or just laying around enjoying the weather.



We all enjoyed a great lunch of bean, cornbread and some cooked cabbage with vegetables and summer sausage. And don't forget all the great deserts and fruit dishes available also.

Shirley is a quilter and has just recently gone from hand quilting all her quilts to using a long arm quilting machine. She had just taken one off the machine and was showing us the lovely design.

Meeting continued with forging and visiting on into the afternoon. We hope everyone that came enjoyed their time at Bob's and Shirley's place, we know we did.

The next meeting day for the SC region is the picnic. Find more information about it in this newsletter. Hope to see everyone there.



TEXAS BBQ FORK by Bill Clemens

18" to 24" of $\frac{1}{4}$ " \square or \circ

HOOK END

HANDLE END

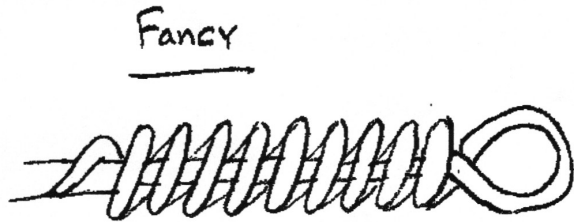
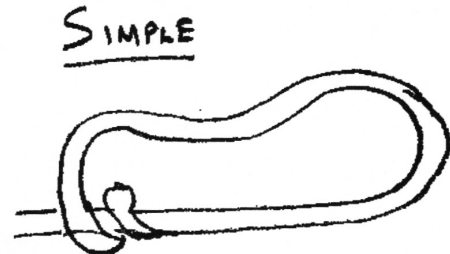
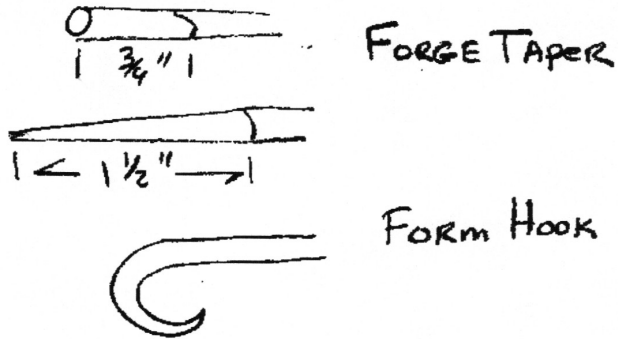

DECORATE the BAR between the hook + handle

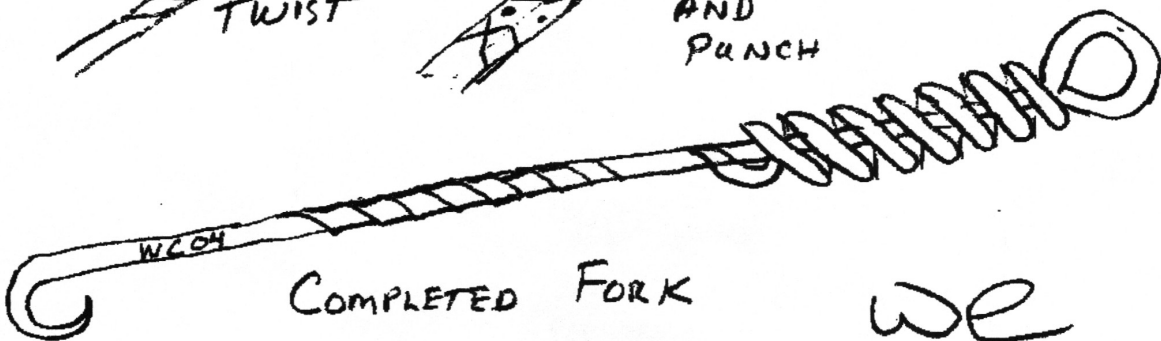

Reprinted from the Hammer & Tong newsletter. March/April 2004
The Blacksmith Guild of Central Maryland, Inc.

CAMPING GEAR

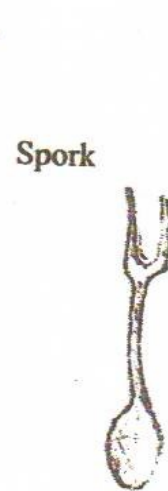
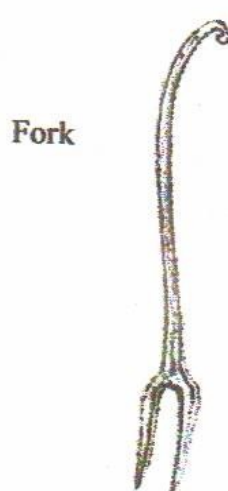
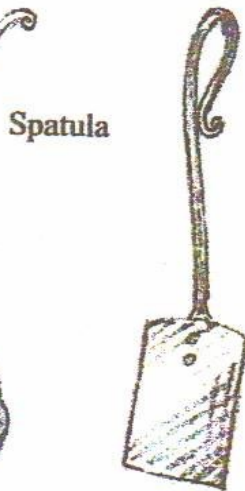
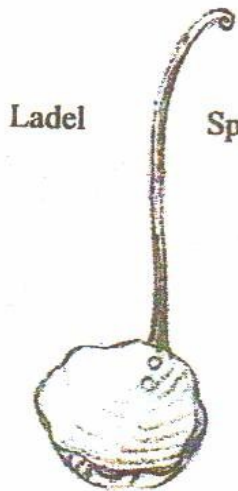
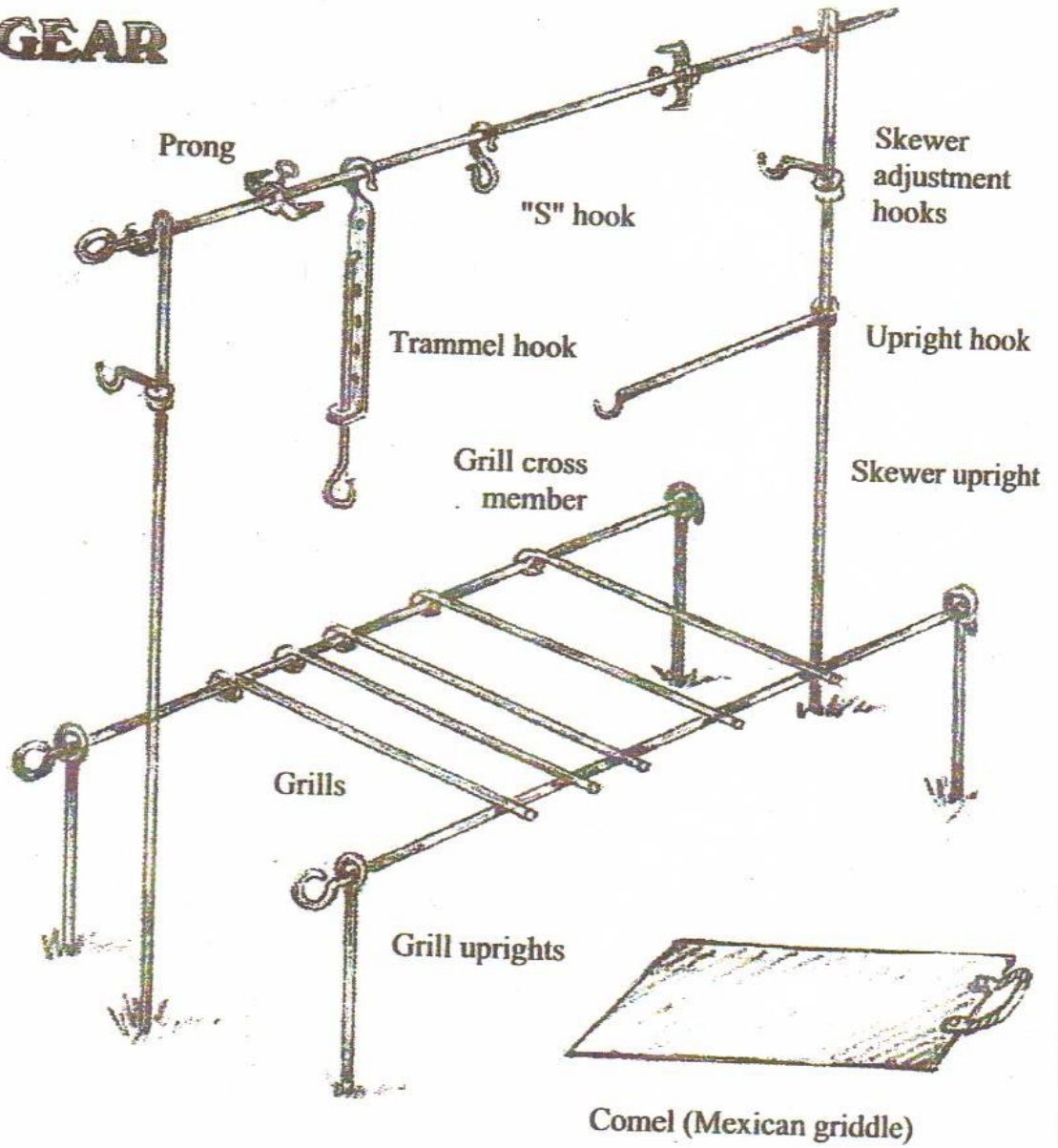
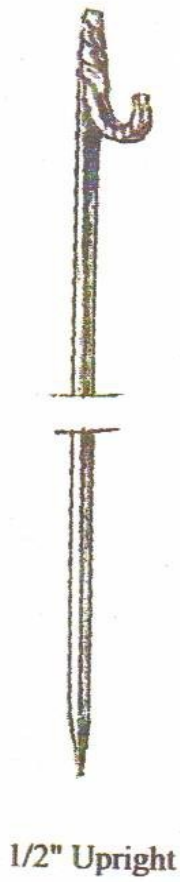

Packers small camp kit

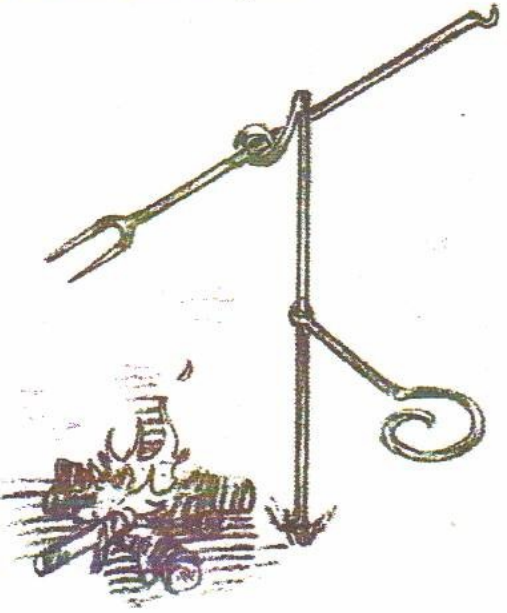

Squirrel cooker

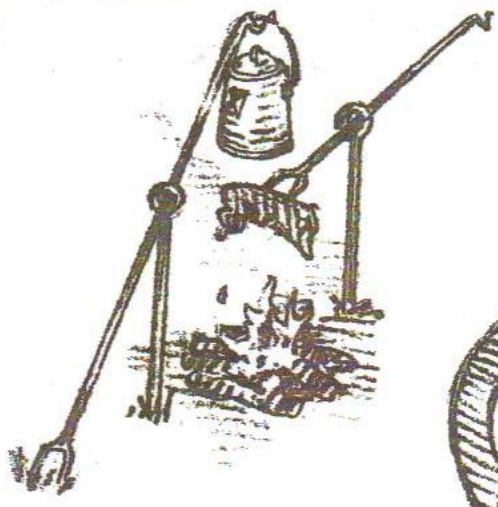

Musket tool

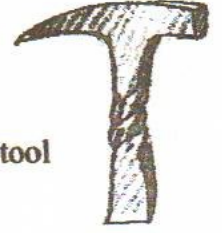

Pot trivet

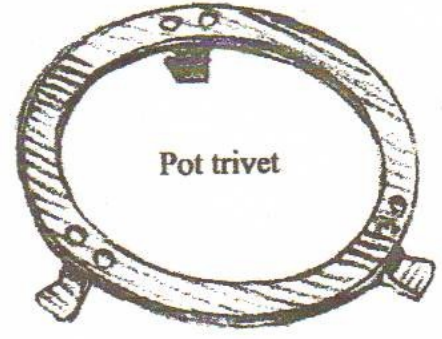

Cavalry picket pin



Packers lead ladle

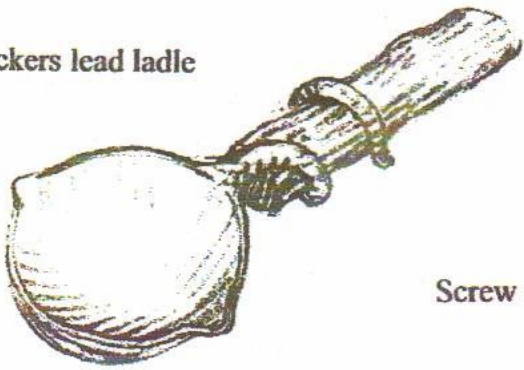

Screw driver



Trammels



Making bar locks for skewer adjustment, and upright hooks. Wrap drawn end of hook (1) around 1/2 upright (2).

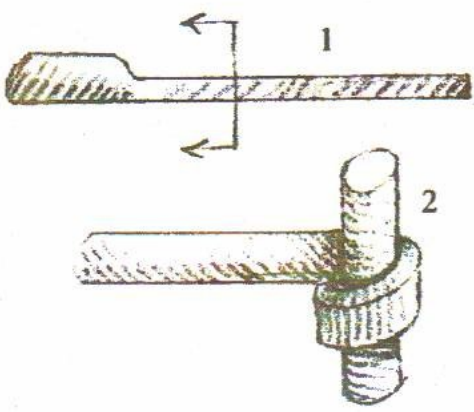

3/16" x 3/4"



3/16" x 1 1/4"

3/16" x 1"

1/4" Round

Iron

TRIVET of the MONTH

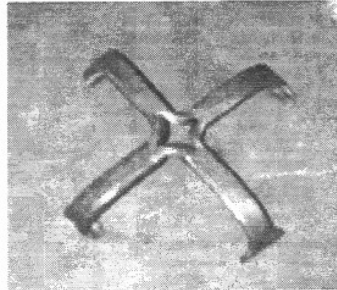

I guess this month's trivet is really a "quadrivet", if there is such a thing, since it has four legs instead of three. I'm sorry I didn't find out who made it, but I saw it in Bob Becker's Class at the Folk School. I found it interesting because it utilizes a technique that has been used most often in making decorative crosses. It is usually credited to Cristoph Friedrich, and it was popularized by its use in frequent demonstrations by Francis Whitaker.

(Doug Merkel's article on the use of the technique in making small crosses was carried in the *Hot Iron Sparkle* for July/August 2000, page 13.)

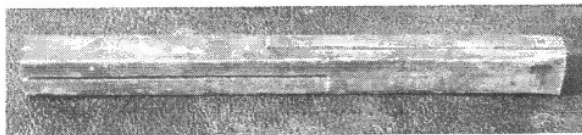

When I set out to reproduce the trivet I took a piece of 3/4" square stock 9" long. (I think 5/8" x 8" would have been better.) I sawed 5" on the center line of two adjoining sides from opposite ends. This gave a 1" overlap of the saw cuts. The amount of

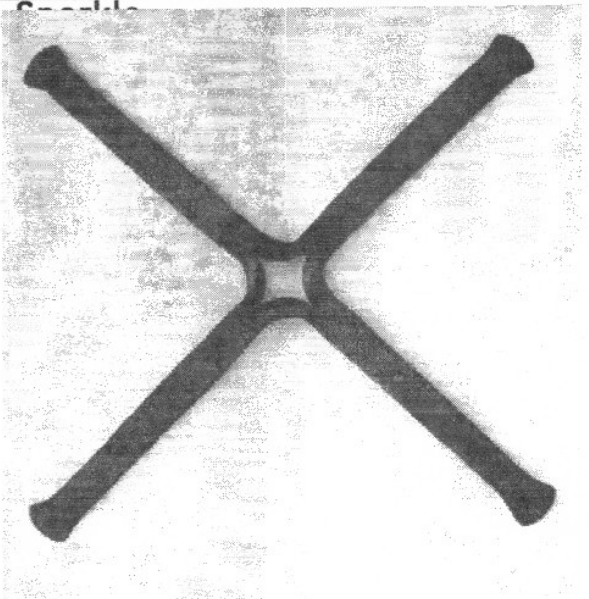

overlap controls the size of the hole that will open up. Of course, the splitting can be done with a hot cut if you don't have a banc saw available and are not eager to saw that much with a hacksaw.

I then drew out the arms and flared the ends slightly. Turning a small scroll on the ends and bending over about an inch and a half created the feet for the trivet.



This is a neat project that can be done in a couple of hours. Grab some metal and get with it!

Bert

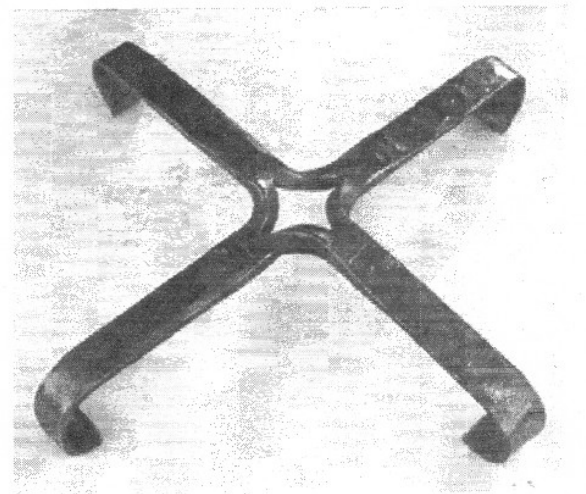
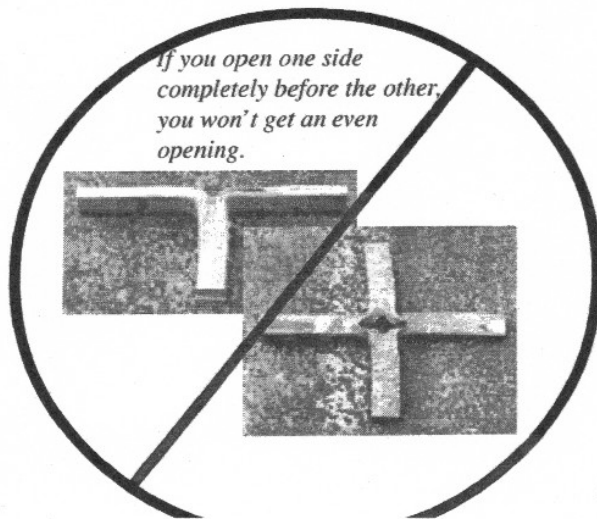

SCABA Shop and Swap

For Sale:

6" round nosed pliers (great for putting scrolls on small items) \$5.00 each. Brooms tied, \$25.00 on your handle **(extra charge if I have to make handle longer)**

Contact Diana Davis at Diana.copperrose@gmail.com

For Sale:

24"(wide) x 1"(thick) Ceramic fiber blanket (similar to Kao-wool) \$1.00 per inch of length. Twisted solid cable 1/2" diameter \$2.00 per ft.

Contact Larry Roderick at 940-237-2814

Wanted:

Advertising Coal Hammers, Contact Mike George at 1-580-327-5235 or o Mike-Marideth@sbcglobal.net

Club Coal

Saltfork Craftsmen has coal for sale. Coal is in 1-2" size pieces The coal is \$140.00/ton or .07 /pound to members **No sales to non-members.**

NW Region coal pile is located in Douglas, OK. If you make arrangements well in advance, Tom Nelson can load your truck or trailer with his skid steer loader for a fee of \$10 to be paid directly to Tom. Tom has moved his skid steer and must now haul the loader to the coal pile to load you out, hence the \$10 charge. You may opt to load your own coal without using Tom's loader. The coal can be weighed out at the Douglas Coop Elevator scales. Contact Tom Nelson (580-862-7691) to make arrangements to pick up a load. Do not call Tom after 9 PM!! Bring your own containers and shovels. Payment for the coal (\$.07 per pound) should be made directly to the Saltfork Treasurer.

NE Region coal location: Charlie McGee has coal to sell. He lives in the Skiatook, Oklahoma area. His contact information is:

littleironworks@gmail.com or
(home) 918-245-7279 or (cell)
918-639-8779



Show your pride in SCABA.

License plates for \$5.00 each.

We have coffee cups for \$9.00 with two images on them and We have a new shipment of caps for \$10.00. There will be caps at the SC meetings and-Dan Cowart has cups and caps for the picnic.



SCABA swage blocks

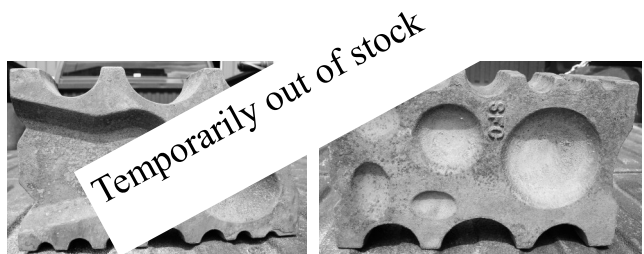

SCABA Floor Cones are now available from Bill Kendall, Byron Donor and Gerald Franklin. The price is \$200 plus shipping and handling.

Sell and Repair Power Hammers (Little Giant) in Tioga Texas. 1-940-580-0032 Ask for Pierre

For sale: 2- 25# Little Giant

1- 50# Little Giant

All new parts, Call for prices...1-940-580-0032 ask for Pierre

Saltfork Craftsmen Artist Blacksmith Assoc.Inc.
10380 N. 4010 Road
Wann, Okla.74083

U S Postage Paid
Non Profit Organization
Permit #8
Sterling Ok.
73567

Address Service Requested

