

Saltfork Craftsmen Artist-Blacksmith Association

July 2021



**A few of the happy new smiths (Tulsa Boy Scouts) fired up about learning to forge for their merit badges with J.J. McGill, Ricky Vardell, Mountain John Cook and Terry Jenkins in Sulphur, OK.
(See Page 14.)**

**Saltfork Craftsmen
Artist-Blacksmith Association
Officers and Directors**

President/West Workshop Coordinator:

Mandell Greteman 580-515-1292
409 East Broadway
Foss, Okla. 73647 mandell01@windstream.net

Vice-President/Conference Chair:

JJ McGill 580-369-1042
5399 Pete Nelson Rd.
Davis, OK 73030 jjmcgill88@yahoo.com

Director:

Byron Doner 405-650-7520
6520 Alameda
Norman OK 73026 byrondoner@esok.us

Director:

Rory Kirk 580-497-6426
501 S 3rd Street
Cheyenne, OK 73628 ershkirk@gmail.com

Director/East Workshop Coordinator:

Brad Nance 918-774-4291
106570 S. 4690 Rd
Sallisaw, OK 74955 bradley.nance@cnet.com

Director:

Eric Jergensen 405-414-8848
625 NW 18th
Oklahoma City, OK 73103 gericjergensen@gmail.com

Director:

Russell Bartling 918-633-0234
70 N 160th W. Ave
Sand Springs, Ok 74063 rbartling@ionet.net

Assignments:

Secretary:

Carol Doner 405-760-8388
6520 Alameda
Norman, OK 73026 caroldoner7@gmail.com

Treasurer:

Teresa Gabrish 405-824-9681
322 Washington Ave
Blanchard, Ok 73010 tgabrish@gmail.com

Editor/Regional Meeting Coordinator:

Russell Bartling 918-633-0234
70 N 160th W. Ave
Sand Springs, Ok 74063 rbartling@ionet.net

Webmaster:

Dodie O'Bryan
Pawnee, Ok scout@skally.net

Librarian:

Don Garner 580-302-1845
23713 E 860 Rd
Thomas, OK 73669
Call or Text. If you get voice mail, please leave a message.

Editor's Notes:

With all of the Covid cancellations and shut downs over the last year and a half, memberships have shown a drop for many blacksmith organizations - including Saltfork. But it seems that meetings and events are coming back around the country. Hopefully, a corresponding enthusiasm for forging and club memberships will also show a similar bounce back soon.

Most of the organizations like Saltfork operate because volunteers offer up their time to make them work and because generous members donate tools and projects for auctions, raffles, etc. to offset all the operating costs. In the times of low membership, those donations are even more critical than ever.

For those of you who have donated items, thank you on behalf of all of Saltfork!

-Russell Bartling, Editor

**** SCABA Board of Directors
Meeting ****

There is a Board of Directors meeting scheduled for **2:00 PM Sunday, August 8th, 2021** at Byron Doner's shop in Norman.

Board meetings are open to any member to attend. This is the best place to offer any comments, ideas or criticisms you have on how your club operates. Feel free to attend. If you plan to attend and have an issue that needs addressed, please send your topic(s) to the Secretary, Carol Doner, to get on the agenda prior to the meeting date. - *Editor*

The Saltfork Craftsmen Artist-Blacksmith Association, a non-profit organization Our purposes are the sharing of knowledge, education and to promote a more general appreciation of the fine craftsmanship everywhere. We are a chapter of the Artist-Blacksmith Association of North America.

Material from this newsletter may be freely copied without permission for non-profit purposes. Please credit the author and this publication.

Visit our Saltfork Craftsmen Website:
www.saltforkcraftsmen.org

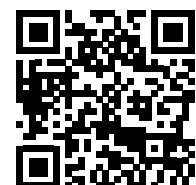

President's Notes:

Hello everyone.

Well, another month has flown by. I hope everyone is getting back to normal as much as possible. I hope you are getting to blacksmith as much as you want.

We are moving forward with our annual conference. It will be at the tractor show grounds in Sulphur again this year. That venue has been working out very well. Our newest director, Brad Nance, is making the toolbox for the conference. We need to make or gather up tools for it to raffle off. Having a good toolbox helps make a good conference. I look forward to seeing everyone having a good time again at this year's conference. We will still need all the help we can get to setup/takedown and run the conference.

I hope everyone is thinking about sponsoring a meeting. It seems to help grow the club and keeps us learning from each other.

Rory Kirk and I went and bought a couple of tons of coal from the new local supplier to see how it works. The BTU content is about the same as what we have been using. I haven't gotten to use any yet but it looks pretty good if that means anything. I am going to take some to our meeting at Elk City and let people try it out. Hopefully we like it. I'm sure there is something we won't like but we don't have much to choose from at this time.

Keep your forges clean.

Thanks, - Mandell



All Regional Meetings are Free to Attend and are Always Open to Any Member or Guest...

New to Saltfork or just want to check out Blacksmithing but don't know where to start? These meetings are a great place for new members or guests who just want to see what it is all about to come network with like-minded people. If you want some pointers on how to get started, there is always someone happy to help get you started hammering. And guests are always welcomed.

Want to host a meeting? The meeting hosting form can be found on the last page along with membership application form. If you want to host a meeting in any area, please fill out one of the host forms on the website under the calendar section or in the newsletter and e-mail the information or mail the hard copy form in as soon as possible. If you mail a form, please call or e-mail to verify that it is received. E-mail is the most convenient for me, but you can also phone in the information if you prefer. The sooner the meeting is scheduled, the more time there is to get the word out to potential attendees. -Russell Bartling 918-633-0234 or rbartling@ionet.net

What's My Region?

The four main regions are currently defined within the state by being separated by I35 and I40. (For example, the NW region is anything north of I40 and west of I35.)

All meetings are encouraged. These boundary definitions and regional meeting dates are a suggested framework to facilitate orderly meeting scheduling, planning and promotion with a minimum of overlaps and a maximum exposure to the greatest number of members. Not all meetings fit precisely within a rigid boundary definition and members in an area may want to hold meetings on a date that doesn't match their physical region or at a location other than their own region. This may be especially true in the center of state for areas that are close to the I35 and I40 boundary crossing. Special events such as shows, fairs, etc. may also dictate adjustments to the meeting dates within a region.

SCABA Regions

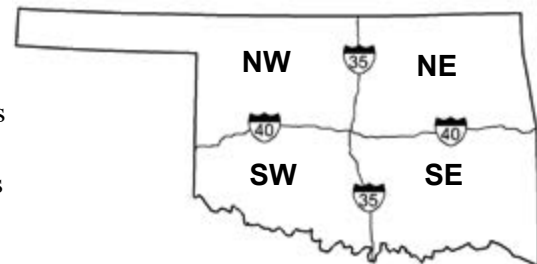

The regions are meant to be a simplification and clarification to the regional boundaries rather than a rigid restriction to any meeting scenario. ***Saltfork members all belong to one club.*** Regional boundaries are not intended to imply division within the club, but are intended to help spread distribution and promote monthly meetings.

Safety

Blacksmithing can be an inherently dangerous exercise. There is no substitute for personal responsibility and common sense and no list of safety rules can adequately cover every situation. Every person who attends a meeting, demonstration or event sponsored by the Saltfork Craftsmen Artist Blacksmith Association (SCABA) or its members does so at their own risk and assumes all responsibility for their own safety needs. The SCABA organization, its officers, members, demonstrators, volunteers and guests disclaim any responsibility for any damages, injuries, or destruction of property resulting from the use of any information or methods published or distributed by SCABA or demonstrated at workshops, meetings, conferences or other events. SCABA recommends proper attire and safety gear and standard shop safety procedures appropriate for blacksmithing and shop work during any event where blacksmithing and other related methods are involved. Safety attire includes, but is not limited to, appropriate clothing, eyewear, hearing protection, gloves, and face shields when appropriate. It is every individual's responsibility to provide for their own safety, to determine what safety gear is appropriate for each situation and to provide, maintain and use that gear as appropriate for each individual situation.

2021 Workshop Schedule

The Board of Directors and the Workshop Coordinator are always looking for feedback from members on what workshops you would like to see from fundamentals to advanced. Please let them know! If there is group interest in a specific workshop topic, they will work hard to try to make it happen.

Beginner Blacksmith Workshop - Saturday, July 31st:

There will be a Beginner Blacksmith Workshop July 31st at the Route 66 Museum Blacksmith Shop in Elk City, OK.

The class size will be limited to 10 people so if you are interested secure your place in the class as soon as possible.

Contact Mandell Greteman at 580-515-1292 to register for the class or if you have any questions.

Have an idea for a workshop or class? If you have an idea for a workshop that you would like to attend (or teach), please let the workshop coordinator know so that details for time and place can be worked out.

******NEW******

We now have two workshop coordinators:

**Western Areas: Mandell Greteman is the SCABA Workshop Coordinator.
Contact Mandell at 580-515-1292.**

**Eastern Areas: Brad Nance is the SCABA Workshop Coordinator.
Contact Brad at 918-774-4291.**

Coronavirus Safety Concerns/Event Cancellations:

With recent developments concerning COVID19, a large number of blacksmithing related events have been canceled for safety reasons. It will be more important than ever to stay posted with websites, social media, etc. and to double check before assuming events will be held.

-Russell Bartling, Editor

2021 REGIONAL MEETING SCHEDULE

NE Region (1st Sat)	SE Region (2nd Sat)	SW Region (3rd Sat)	NW Region (4th Sat)
Jan 2nd (Open)	Jan 9th (Open)	Jan 16th (Open)	Jan 23rd (Open)
Feb 6th (Open)	Feb 13th (Open)	Feb 20th (Open)	Feb 27th (Doug Hyde)
Mar 6th (Open)	Mar 13th (Open)	Mar 20th (Open)	Mar 27th (Mandell Greteman)
Apr 3rd (Don Garner)	Apr 10th (Diana Simon)	Apr 17th (Open)	Apr 24th (SCABA Picnic!)
May 1st (Open)	May 8th (Open)	May 15th (Open)	May 22nd (Rory Kirk)
Jun 5th (Open)	Jun 12th (Open)	Jun 19th (Open)	Jun 26th (Everett Timmons)
Jul 3rd (Matthew Ragnar) Crowson)	Jul 10th (Open)	Jul 17th (Open)	Jul 24th (Open)
Aug 7th (Diana Simon)	Aug 14th (Open)	Aug 21st (Open)	Aug 28th (Open)
Sep 4th (Tracy Cowart)	Sep 11th (Open)	Sep 18th (JJ McGill)	Sep 25th (Ron LehenBauer as Host - Don Garner as Contact Person)
Oct 2nd (Open)	Oct 9th (Conference Setup)	Oct 16th (Conference Weekend)	Oct 23rd (Rory Kirk)
Nov 6th (Diana Simon)	Nov 13th (Open)	Nov 20th (Open)	Nov 27th (Open)
Dec 4th (Open)	Dec 11th (Open)	Dec 18th (Open)	Dec 25th (Christmas Day)

2021 Fifth Saturdays:

January 30th (Open)

May 29 (Boy Scout Meeting at Murray County Antique Tractor Show Grounds.)

July 31st (Beginner Blacksmith Workshop - Elk City)

October 30th (Open)

July 2021

NE Regional Meeting July 3rd: Will be hosted by Matthew (Ragnar) Crowson at 5908 E Tecumseh St, Tulsa, OK 74115

Trade item is a BBQ utensil.

Lunch will be provided but please bring a side dish or desert to help out. Contact Ragnar at 918-855-8250 if you have questions.

SE Regional Meeting July 10th: Open.

SW Regional Meeting July 17th: Open.

NW Regional Meeting July 24th: Open.

August 2021

NE Regional Meeting August 7th: Will be hosted by Diana Simon and the Cherokee Strip Historical Society at the new Blacksmith Museum and Shop. 2617 W. Fir Ave, Perry, OK 73077. The shop is located approximately 1/4 mile east of Exit 186 from I-35 on north side of the road (Hwy 64 or Fir St.)

The trade item is a Friedrich's Cross. The meeting is planned to start at 9:00 AM. Lunch will be provided. Please bring a side dish or dessert to help out.

Contact Diana Simon at 580-572-8290 or dsimon@gmail.com if you have questions.

SE Regional Meeting August 14th: Open.

SW Regional Meeting August 21st: Open.

NW Regional Meeting August 28th: Open.

The Saltfork Gate Project Still Needs More Rings!



This is a community project that is open to all Saltfork members regardless of skill level or experience. There is still room for more rings. You can see more details about the project in any of the past newsletters from August 2019 through January 2021.

Contact Mandell if you have any additional questions or to find out where to obtain one of the project rings: **Mandell Greteman 580-515-1292.**

2020 SCABA COVID CONFERENCE: Watch for the Auctions on E-bay!

Thank you to everyone who donated items for an online auction to help make up for the canceled conference in 2020!

We received a number of great items and Eric Jergensen has started listing the items on E-bay on behalf of Saltfork. The items are not all being listed concurrently but are, instead, being spread out to help build positive seller feedback and to have more time to build awareness of the listings.

To date, the decorative heart/flowers by Terry Jenkins, the diagonal pein hammer by Mandell Greteman, and the helmet from EWS have been sold. There are more great items coming up!

If you are interested in bidding, check E-bay for the seller "saltfork0." Go to the advanced search option and enter saltfork0 in the seller ID field. (That is saltfork with a zero at the end.) Members can watch their e-mails for an announcement with links from Saltfork when the listings go live. You can save the seller on E-bay to receive notifications of new listings. If you are new to E-bay, creating an account and bidding is easy and you can get notifications as the auction progresses.

Here is a link to the Saltfork listings (current at the time this newsletter is being produced. Hopefully, this link will remain valid as listings change) :

https://www.ebay.com/sch/saltfork0/m.html?item=373631337087&hash=item-56fe29c27f%3Ag%3AzBgAAOSwUWpg2oUw&rt=nc&_trksid=p2047675.l2562



Thank you to everyone who donated items and thank you to the bidders!



Oklahoma State Fair is Back!

Hello Saltfork Club members! It is time to dust of your equipment and get back in the swing of things. The Oklahoma State Fair is set to take place this year after a year off from Covid.

Mark your calendars for the upcoming demonstration days:

Thursday, September 15 through Sunday, September 25, 2021

Like most things, the State Fair Budget was cut. But they secured the Frontier Experience and our demonstrators! Let me know sooner, rather than later, if you are interested in volunteering for this event. You will receive free admission and premier parking for the days you demonstrate.

This is a great opportunity to draw members into our club while brushing up on our skills. We are seeking those who would like to help promote and talk about the club by demonstrating to fairgoers. In years past we have also had a complimentary hotel for those traveling a greater distance from out of town. Consideration is given on a first requested and distance traveled consideration.

If you would like more information about this fun event, please contact Richard Blasius 405-881-0804 or his wife Michele 405-550-9850.

SALTFORK CRAFTSMEN 2021 STATE FAIR CALENDAR

SEPTEMBER

SUNDAY	MONDAY	TUESDAY	WEDNESDAY	THURSDAY	FRIDAY	SATURDAY
				FIRST DAY 16 * * *	17 * * *	18 * * *
19 * * *	20 * * *	21 * * *	22 * * *	23 * * *	24 * * *	25 * * *
LAST DAY 26 * * *						

Scheduling: Richard Blasius 405-881-0804
Michele Blasius 405-550-9850

Around the State...

NW Region May Meeting: Was hosted by Rory Kirk at the Route 66 Museum Blacksmith Shop in Elk City. The trade item was a keychain. From Rory:

We had a good meeting Saturday at the blacksmith shop at the Route 66 museum in Elk City.

We had a 22 people show up at the meeting and several visitors come through admiring our work and the museum.

We had a good lunch (pork ribs and smoked sausage - yum.) We even had a couple of visitors eat with us - they couldn't pass up BBQ.

I'd like to say thank you to everyone who attended the meeting and who helped with the food and clean up.

Thank you, Rory Kirk









Around the State (Continued)...

May 29th Fifth Saturday Boy Scout Meeting: (See Following Page)

NE Region June Meeting: No meeting was held.

SE Region June Meeting: No meeting was held.

SW Region June Meeting: No meeting was held.

May 29th Fifth Saturday Meeting:

“Tulsa Boy Scout Blacksmith Camp Out Year Eight in Memory of Jim Dyer”

Well the holiday weekend started off with a little rain Friday evening as the Scouts arrived at the Tractor Club Show Grounds. But it soon stopped. They were able to get all their tents set up and almost everyone to bed before 10 pm. We started off Saturday with Scouts cooking breakfast. We had planned to start forging about 9 AM but it was more like 10 before we got started good. The Scouts were to make a Spatula and Ladle for camp cooking.

JJ demonstrated how to make two simple handles but had several different ones for display. The Scouts were challenged to make up there own.

It seemed as if we just got started good when the lunch bell rang. For lunch, Chuck Ogdan had smoked pulled pork butt for BBQ sandwich's. There were a variety of chips to go with fruit or JJ's mom was bring her home-made fudge brownies straight out of the oven to the group. There was plenty of Iced Tea and water to drink. Thanks to Chuck and Nana Patsy, Aunt Becky and Ashley for setting up the food and making all the brownies. I think I heard they made eight pans full.

So with their bellies full and on a chocolate high, the hammers started to swing again about 1pm. They hammered all afternoon. Everyone was able to make more than just the spatula and ladle as you can see by the pictures. We finally put the last forge fire out around 8pm. I think the young ones would have hammered all night!

A Big THANK YOU goes out to Ricky Vardell, Mountain John Cook and Terry Jenkins for coming to help me work with the Scouts.

A Special Thank You to Ricky for pre-cutting out the Spatulas and Ladles for Us. - J.J. McGill









Angle Iron Butterflies or Moths~

By Larry Carrigan, a MABA member

I like to include “critters” when doing flower and natural themed sculptures, they add a lot of interest to the project and are fun.

There are lots of ways to make butterflies but this is my method and it also uses up my small pieces of angle iron. Today’s “critters” are made from $\frac{1}{8}$ " equal-leg angle iron. Common sizes available on the market are $\frac{1}{2}$ ", $\frac{3}{4}$ ", 1", $1\frac{1}{4}$ ", $1\frac{1}{2}$ ", $1\frac{3}{4}$ " and 2". $2\frac{1}{2}$ " and 3" angle are available in $\frac{3}{16}$ " thickness. My favorite size to work with is $1\frac{1}{2}$ " and 2", the smaller sizes are good for moths but this size is more realistic.

Project material:

2" x 2" x $\frac{1}{8}$ " angle iron by $1\frac{1}{2}$ " to 3" long

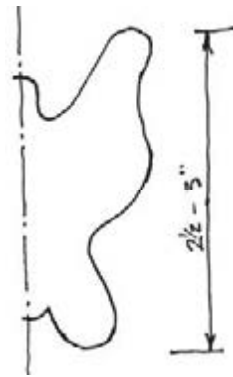

Draw a pattern to your liking (only have to do half).



Flatten the angle iron leaving a prominent center rib.

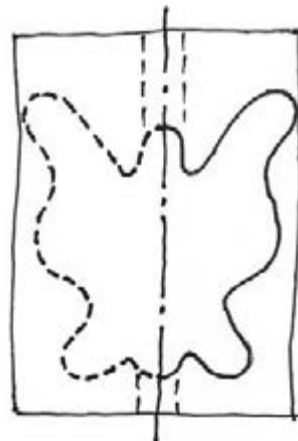

Trace your pattern on both halves and cut out. Chisel, band-saw or plasma cut.

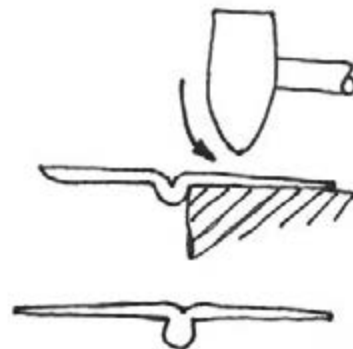

With the rib held tight to the edge of the anvil, draw the wings down to about $\frac{1}{16}$ " with a cross-peen.

Decorate and texture the wings with punches and chisels or include piercings.



Re-fold the wings to a natural angle.

Attach with rivet or tack-weld.

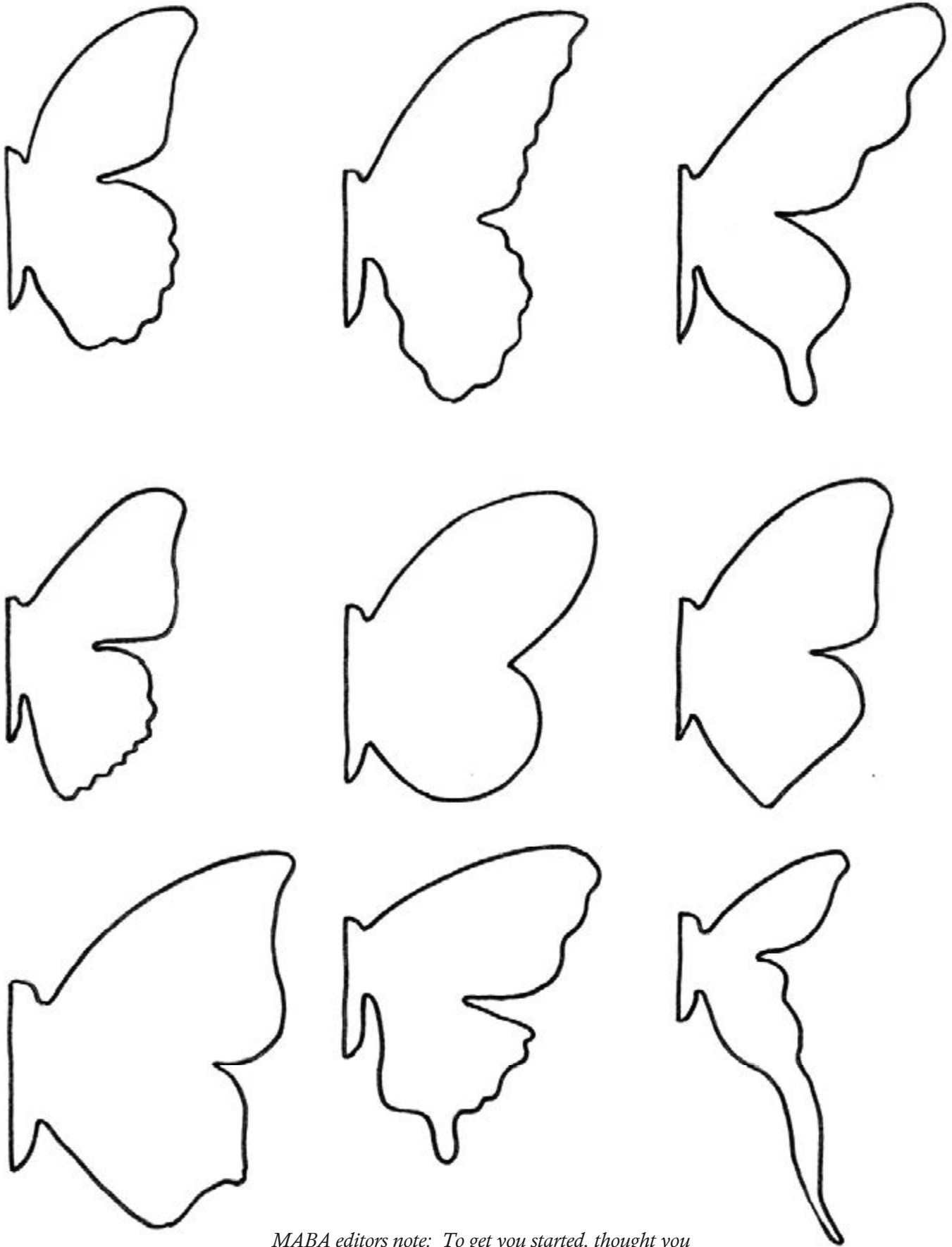

MABA editors note: To get you started, thought you would enjoy some ideas for butterfly patterns.



*This article is reprinted with permission from the Michigan Artist Blacksmith Association
"The Upsetter" newsletter Jul-Aug 2021.*

Leg Vice Filing Helper

Here is a vise tool you might be interested in. It was presented on Facebook by Herb Gravitt of the Appalachian Area Blacksmith Chapter. The design is a Terry Sheridan post vise filing jig project. The work piece to be filed will be supported by the adjustable jig while being secured by the post vise jaws. Terry was kind enough to talk me through this project while sketching it out and showing me photographs of his filing jig. Maybe it will spur you into making one of your own! Barry

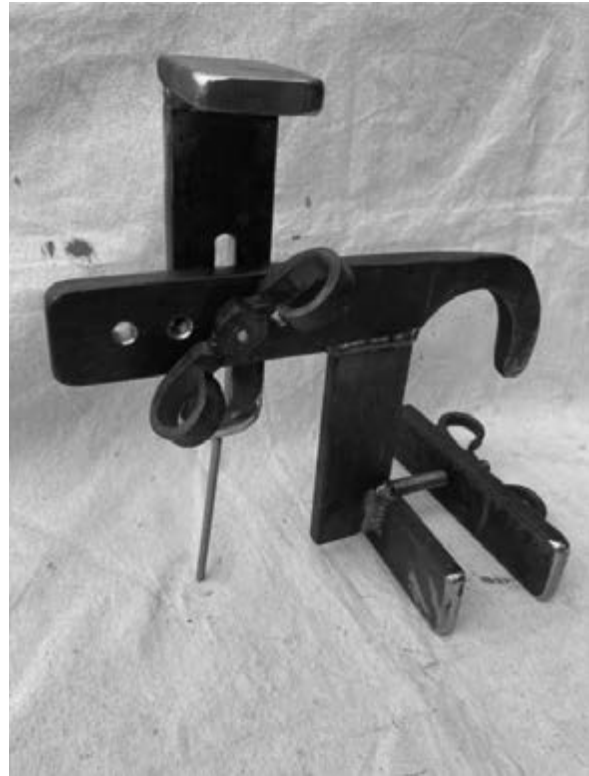
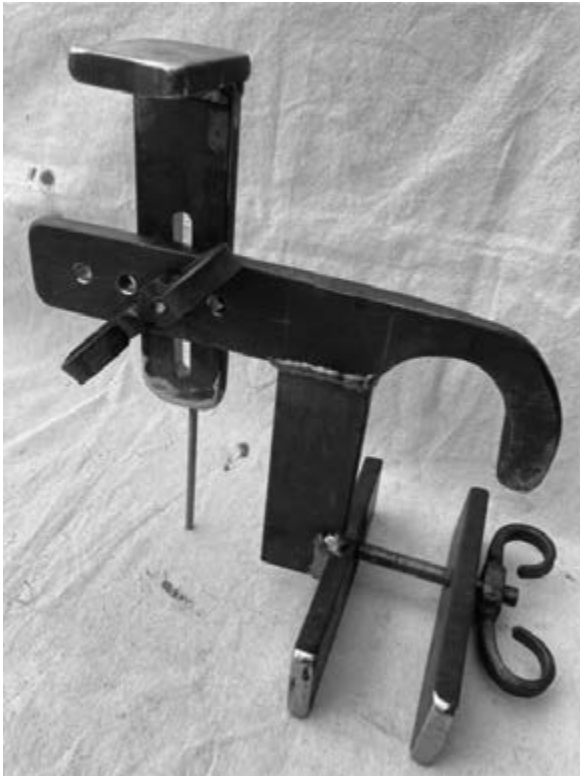

Quick Project: Adjustable Punch/Chisel Holder

By Gerald Franklin

The photo tells the story. There are no critical dimensions so use what scrap or stock you have on hand and adjust the dimensions if required to suit what you have and to fit your chisels or punches.



← **Opposite Page:** This article is reprinted courtesy of the Philip Simmons Artist Blacksmith Guild "On the Anvil" newsletter, September/October 2020. This filing helper reminds me of a similar helper that Peter Ross shows in his "Popular Woodworking" DVD on forging a compass. His helper mounted to the workbench just beside the vice. The essential utility of this helper may not be completely obvious at first but, supporting any overhang greatly reduces vibrations that make filing difficult. And, as Peter Ross demonstrated, it is also very difficult to hold a long, skinny, tapered piece in the vice for easy filing without having some kind of outboard support like this. - Editor



ABANA'S Education Committee Announces the National Curriculum

From ABANA: We have some exciting news from the Education Committee; ABANA has fully adopted the National Curriculum (NC), based on the curriculum of the CBA (California Blacksmith Association).

As our core mission is to perpetuate the noble art of blacksmithing, we recognize it's incumbent as a national blacksmithing organization, to share a successful and practical working curriculum with members, affiliates, and the blacksmithing world at large.

What is the National Curriculum? The NC is a departure point for those that seek a structured program of study that can be used at schools, conferences, meetings, and individual shops through one on one, small groups and self-guided study.

We present the curriculum as one way to learn blacksmithing, but certainly not the only way. From this set of goals, lessons, and benchmarks, smiths at any skill level can pick this up and continue their education. The curriculum provides the framework for the student to progress through increasingly challenging projects that focus on the skills expected of a journeyman smith, culminating with the Level III Grille. - ABANA Education Committee.



If you are interested in finding out more about the curriculum, information on all three levels is available on ABANA's website:

<https://abana.org/abana-curriculum/>

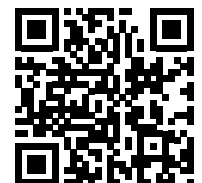

Mark Aspery has shared a series of articles from the CBA related to the Level III Grille Project and its associated tooling. I will include this series in upcoming newsletters for those who are interested. This is essentially the same information that ABANA is adopting and additional information and resources can be found on their website. - Editor

THE CALIFORNIA BLACKSMITH ASSOCIATION

LEVEL III GRILLE



NOTE: This drawing is included to show the dimensions only and may not be printed to scale! If you are going to do this grille, download the full scale drawing from the ABANA website! - Editor

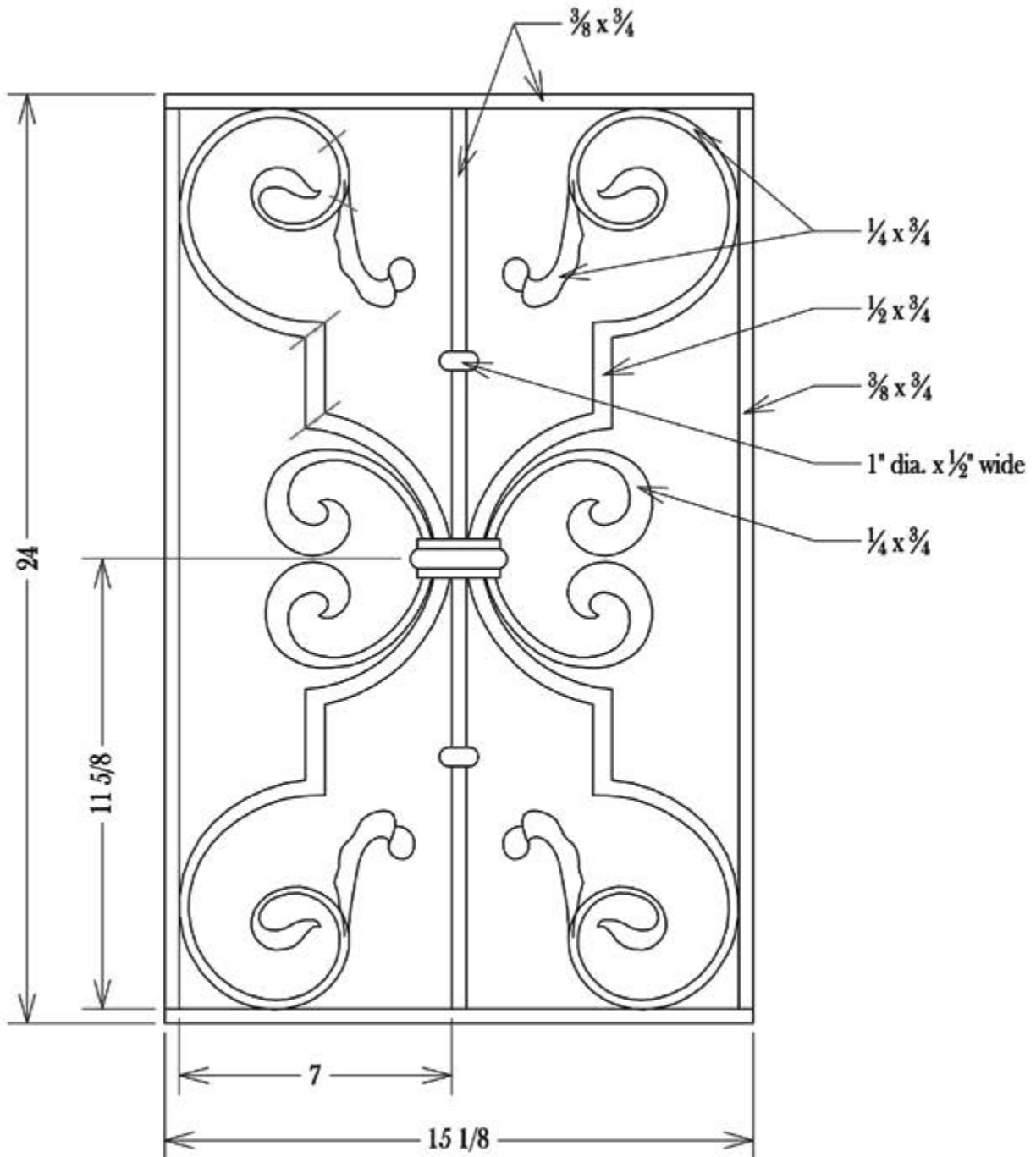

McLellan Blacksmithing
 6961 Horseshoe Bar Road
 Loomis, CA 95650
 (916) 652-5790 Fax (916) 652-5784
 www.McLellanBlacksmithing.com

CBA Curriculum Level III Grille project

Grill		Sheet Number	000
Date	09/08/07	Revised	02/17/11
Scale	3" = 1'-0"	Drawn by	John McLellan

CALIFORNIA BLACKSMITH ASSOCIATION

The Level III Grille Project Mark Aspery

This grille is a rich project for the blacksmith. It requires a broad depth of knowledge and skill to complete it, including toolmaking and subsequent heat treatment, forging to dimension and forge welding.

The grille requires the duplication of the same piece to the same specifications four times, once in each quadrant of the screen.

A copy of the drawing can be obtained from the CBA web site, www.Calsmith.org

Job one, is to transfer the drawing to a piece of rusty sheet metal, so that you can offer up hot metal to check fit, without the drawing disappearing in a ball of flames.

To transfer the drawing, you will need some blackboard chalk, an older file, some sticky masking tape or tack pins, a colored ball-point pen and a welder's silver pencil.

Copy one quadrant for the whole grille because the drawing is a mirror image, top to bottom and left to right. You can flip a scroll around later for fitting into any quadrant of the frame.

Shown is a piece of rusty sheet metal that is just slightly larger than one quadrant of the drawing. You will use this drawing at least four times, so you need it to be durable and storable.

Rub the chalk against the old file while holding it above the back of the drawing. The chalk dust will fall onto the drawing. (fig. 1)

You can chose to chalk a piece of brown paper - such as a re-cycled paper bag from the grocery store. The brown paper can act as old-fashioned carbon paper, and it's a little softer under the ball-point pen.

The chalk will need to be rubbed into the paper by hand before you turn the drawing over (fig. 2).

Tape or pin the drawing (or drawing and brown bag combo) chalk-side down over the sheet steel (fig. 3). *If the drawing moves as you transfer the lines, it will be nearly impossible to re-align it again.*

Use a colored pen to go around the outside of the components of your drawing. The colored pen allows you to see what you have already done. Missing some of the drawing during the transfer can lead to much gnashing of the teeth! (fig. 4)

There are a number of ways to approach the scroll and leaf combination – for me, I have decided to make the top/end of the scroll and the water leaf from the opposite ends of the same bar. I will then nick, fold and forge weld the middle portions of the bar together later at the anvil.

The leaf and scroll assembly will then be forge welded to the remainder of the scroll stock that leads back to the two upset corners.

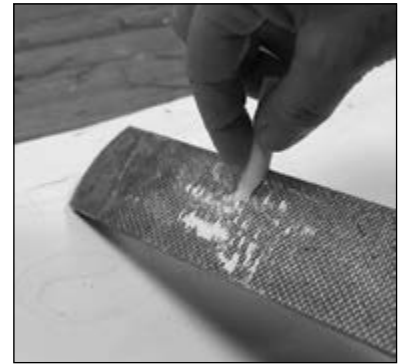

Fig. 1 Apply chalk dust to back side of the drawing



Fig. 2 Rub the dust into the paper- remove excess



Fig. 3 Pin or tape the drawing down over the rusty tin-plate



Fig. 4 Draw around outline with a colored pen

TRANSFERRING THE DRAWING

Before you begin to forge, you need some information for the leaf/top of scroll assembly. You need to know how long a bar to cut in order to make the scroll and leaf.

To determine this information, you will need to create a datum (or starting point) on the drawing. Let's use the area where the bottom of the leaf and the scroll branch as our datum. Mark your drawing accordingly with a line going across the scroll. (Fig. 5)

Measure the length of the scroll and the length of the leaf outwards from this datum point. Flexible wire works well for this, although you can also use a pair of dividers or even a map measuring tool (Opisometer). Set the dividers with a gap of $\frac{1}{2}$ inch so that you don't get too much of an error by measuring the chord rather than the arc of the curve. (fig. 6)

On my drawing, the leaf measures 3 inches from its tip down to the datum and the scroll measures $5\frac{1}{4}$ inches from tip to datum. $8\frac{1}{4}$ -inches overall.

Your drawing may be different depending upon the printing or copying machine.

You want extra bar beneath the datum point on the drawing for the forge weld. I go with about $1\frac{1}{2}$ inches on both the scroll and the leaf sides. 3-inches total.

Why so long, you ask? Once the leaf and top of the scroll are welded together, you'll need to weld them on to the remainder of the scroll. It would be wise to keep the delicate leaf out of the fire as much as possible during this second welding process.

By the time you weld the two pieces of material $1\frac{1}{2}$ inches long together and draw them out a little, they should get to be at least 2 inches long from the datum to the center of the scarf.

Realize that to make the water leaf as shown in the drawing, you will have to taper the end to some degree. The tapering of the bar will lead to an increase in the overall length of the bar.



Fig. 5 Scribe a datum line where the scroll and leaf branch



Fig. 6 Step out from that datum point to the tip of leaf and scroll



Fig. 7 Forge the end to the beveled leaf scroll



Fig. 8 Measure out to the severance point of the bar and mark

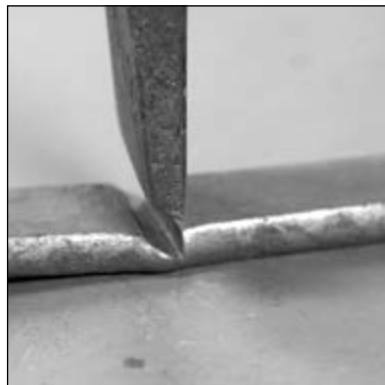

Fig. 9 Cut, leaving the chamfer on the parent bar



Fig. 10 Draw a short, rounded taper to the bar. Maintain stock thickness

CALIFORNIA BLACKSMITH ASSOCIATION

Also note that when you spread the bar to make the leaf, while most of the material will be spread perpendicular to the center line of the bar, some of the material will be displaced lengthways, along the bar, further increasing the length of the bar.

For me, when I spread, I get a constant of about 75% of the expected yield. What does that mean?

The leaf is made from $\frac{1}{4}$ -inch by $\frac{3}{4}$ -inch flat bar. Another way of saying that is four pieces of $\frac{1}{16}$ -inch thick bar, $\frac{3}{4}$ -inch wide.

My leaf will be approximately $\frac{1}{16}$ -inch thick. In theory, I should get a leaf that will be 4 x $\frac{3}{4}$ -inch wide or 3-inches. I don't, I get about 75% or 2 $\frac{1}{4}$ -inches of width, with the remainder of the stock lost to scale and elongation along the centerline of the bar.

The leaf on the drawing measures 3 inches in length. It is necessary to conduct a test piece to see how much each step in the forging increases the length of the bar.

My test pieces resulted in the following:

- Forging the leaf lengthened the bar by $\frac{5}{8}$ -inch
- The scroll end lengthened the bar by 1 inch.

Add those measurement together, and then subtract them from the 8 $\frac{1}{4}$ -inches taken from measuring the drawing earlier.

Then add to that measurement both sides of the material needed for the weld.



Fig. 11 Spread the material for the leaf



Fig. 12 The leaf, forged and formed

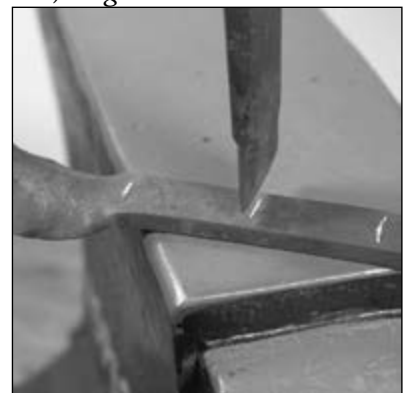

Fig. 13 Nick the bar between the leaf and the scroll

Including the material below the datum for the faggot weld, I need 9 $\frac{5}{8}$ -inch of raw material for the leaf and scroll assembly.

I prefer to work off the end of a longer bar for as long as I can, to negate the use of tongs.

Make the leaf for the blown-over beveled leaf scroll end. *Do not bend the scroll end at the moment.*

Measure down 5 $\frac{1}{4}$ inches from the tip of the leaf to the base of the scroll (datum) and make a mark. Measure out from this point another 3 inches to the base of the leaf and make another mark. Measure out from here to the top of the leaf—2 $\frac{3}{8}$ inches.

Halfway between the base of the scroll material and the base of the leaf material is the point of the nick, for the fold and weld.

Note: The blown over, beveled leaf scroll is archived on the www.calsmith.org web site.

The leaf shoulder, and the bevel to the scroll, are on the same side of the bar.

Once all your marks are in place, then bend the scroll end and bevel the scroll. Don't turn the scroll at this point in time.

Once the scroll is bent and the leaf formed, nick the bar between the bottom of the leaf and scroll on the opposite side of the bar to the beveled side (and hopefully leaf shoulder side). *Fig 13*

TRANSFERRING THE DRAWING



Fig. 14 Fold the leaf back on itself

Fold the bar away from the cut so that the beveled surface of the scroll nests inside the water leaf.

The folded bar needs to be forge welded together. This welded bar will then be forge welded again as a lap weld (drop-tong weld) to the remainder of the scroll assembly coming from the upset corner bends.

Leave the end of the bar that you are welding together thick at the very end – in fact for me, I don't even care if the two sides are welded at this point.

Spend most of your time at the base of the leaf and scroll. The future lap weld will weld and thin down the material at the end of the weld site later. *Fig 15*

Turning the scroll through this weld area is made difficult by the presence of the leaf. This is exacerbated if the weld area is thicker than the scroll end.



Fig. 15 Weld on the back and face of the anvil

Draw down the weld area to a ¼-inch in thickness.

Once the faggot (layered) weld is complete, form the scarf on the end of the bar in preparation for the lap weld to the remainder of the scroll. *Fig 16*

Thinking ahead I will be holding the leaf/scroll assembly in my hammer hand, keeping the larger, heavier piece (the 2 upset corners and remainder of the scroll) in my tong hand.

The leaf scroll assembly has a flat and stable side (the scroll side) and a curved and unstable side (the leaf side). I want the scroll side down on the anvil for stability when I weld on the remainder of the scroll.

Keep the leaf down as you make the step of the scarf. Thus, the slope for the toe of the scarf will go from the scroll side, with the step being on the leaf side. □



Fig. 16 Form the scarf with the step on the leaf side

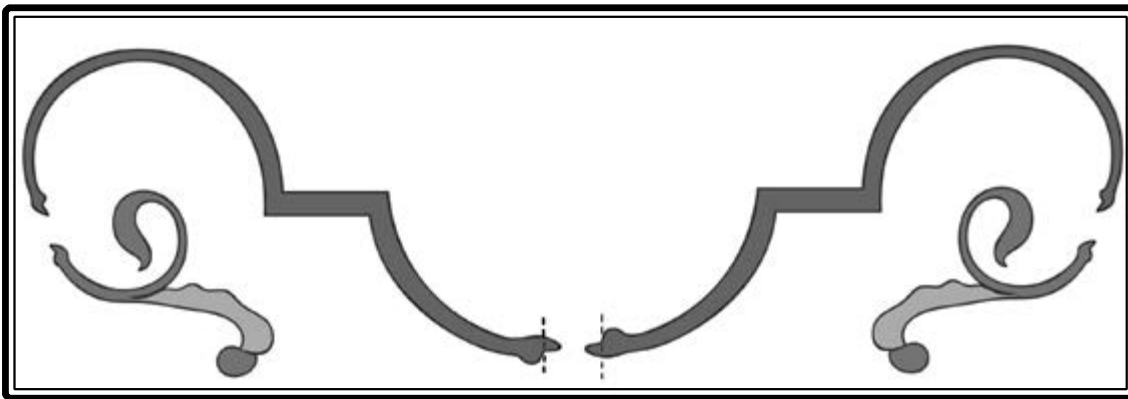

*A breakdown of the scroll assembly
for one side of the grille
D. Carroll image*

*This article is reprinted with
permission from the California
Blacksmith Association - Submit-
ted by Mark Aspery.*

Little Giant Power Hammer Rebuilding Class October 15-17 Nebraska City, NE

Attached (*see next page*) is information for the last Little Giant power hammer rebuilding class that will be taught by Sid Suedmeier, former owner of the Little Giant company. The business has been bought by longtime friends David Sloan and Doug Klaus, and they intend to carry on the rebuilding class.

Thank you so much for your support through the years in promoting the rebuilding class. We hope it will help keep the machines and blacksmithing alive for generations to come.

- Doug Klaus

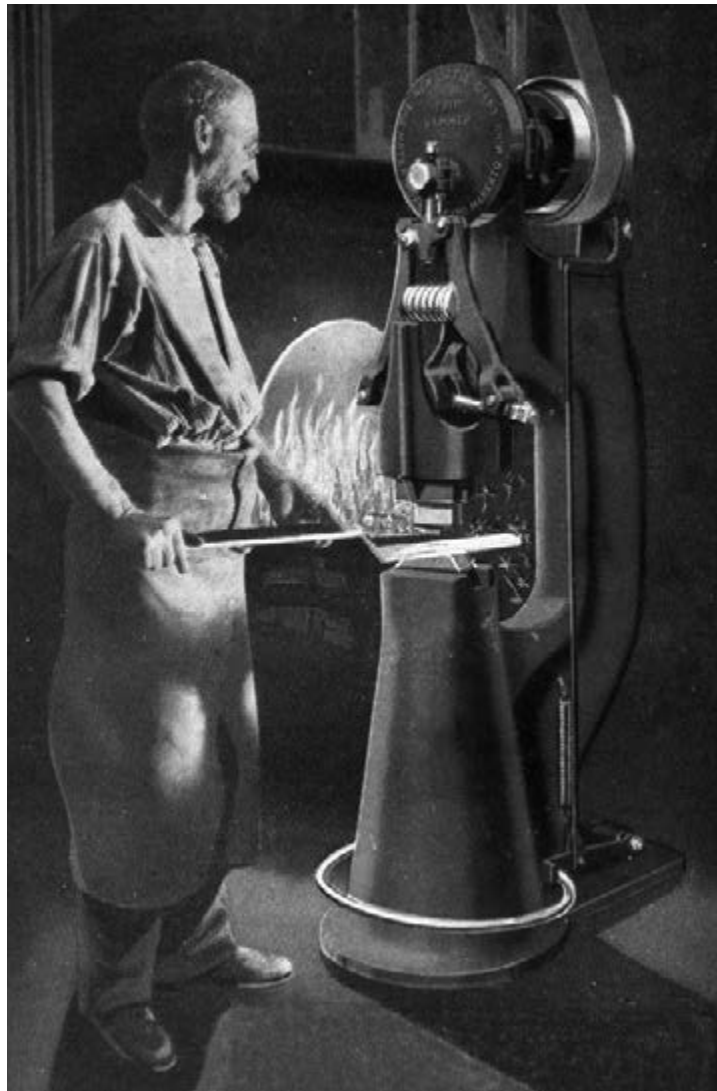

**LEARN HOW TO MAKE YOUR
LITTLE GIANT POWER HAMMER
WORK HARDER THAN EVER!**

In 1991, Sid Suedmeier, having recently acquired the dusty remains of the Little Giant business, hosted his first Little Giant Hammer rebuilding class.

The class and Sid were taught by our good friend Fred Caylor of Zionsville, Indiana, at that time one of few authorities on these antique machines. As Fred grew older, Sid took over teaching the class, and has taught at best count 27 classes.

Sid sold Little Giant, the parts and repair business, to his long time machinist in 2013, and just this year the business made a move to our good and capable friends, David Sloan and Doug Klaus.

This 2 1/2 day class is a hands-on format. You will help transform a 25 LB Little Giant hammer from sloppy to sharp. This is the last class that Sid Suedmeier, intends to teach. He will be handing the reins over to David Sloan, who has attended at least 15 classes and has assisted Sid through the years.

An old style 25 LB Little Giant will be rebuilt during the class, and a new style machine will be on hand to demonstrate proper assembly and adjustment of both styles.

**IF YOU HAVE A LITTLE GIANT, THIS
CLASS IS FOR YOU!**

No experience is required to attend this class. Past students have ranged from age 15 to 90, and from all walks of life. Anyone who wants to learn will benefit from this class. We approach the rebuilding process using tools that can be found in the average home workshop.

If you are in the market to buy a power hammer, this class will make you an educated shopper. If you already own a Little Giant, or any other brand of power hammer, this class will teach you how to get the best performance possible.

The class costs \$95, refundable up to 7 days prior to the class; advance registration is required. We will limit the number of students. The class starts at 9 AM sharp on Friday, and usually ends by Saturday evening. We will be available on Sunday until noon in case we encounter any exceptional problems in rebuilding, and to answer remaining questions.

When we receive your registration we will send you a city map, along with travel and hotel information.

**School Dates
October 15-17**

2021 REGISTRATION

Name: _____
Business name: _____
Address: _____
Telephone: _____
Email address: _____

Since we no longer operate a business, payment needs to be by check or money order. Checks should be made out to Sid Suedmeier.

POWER HAMMER INFO

Brand: _____
Size: _____
Serial Number: _____

Please call or email if you have any questions, or prefer to register by phone. You can reach us at 402.873.6605 or Sidsshop@windstream.net.

Sid's shop is located at 420 4th Corso, Nebraska City, NE 68410.

ABANA Affiliate Newsletter - June 2021

Artist-Blacksmith's Association of North America
47 Walnut Street, Suite 200
Johnstown, PA 15901-1521

Iron to Art Festival Tickets are on Sale, Register Early, Save Over 30%

The dates are set, October 14 through October 16, 2021. ABANA will host the Iron to Art Festival at our new headquarters in Johnstown, Pennsylvania. Tickets are on sale now.

<https://event.abana.org>

Early Registration Discounts Available!

- Member registration: \$125.00 before August 31st. After 8/30 (late registration) \$165.00
- Member Spouse registration: \$50.00 before August 31st. After 8/30 (late registration) \$75.00
- Non-Member registration: \$185.00 before August 31st. After 8/30 (late registration) \$245.00
- Non-Member Spouse registration: \$70.00 before August 31st. After 8/30 (late registration) \$90.00

ABANA would like to interest you in being a Craft Vendor at Iron to Art Festival This is our inaugural event in Johnstown, PA and ABANA wants you!!!!!! We are expecting 500 + visitors to the conference with 5000 visitors to Johnstown itself over this new 3 DAY EVENT and ABANA wants YOU to get in on the action. Rent a 12x12 vendor booth for the low cost of \$250 (for all 3 days), comes with electricity and if you're performing live demonstrations for your craft you will receive an ADDITIONAL ½ space for free to showcase your skills. There will be visitors and exhibitors from far and wide, what a perfect venue to showcase your crafts and passions. See ABANA.org, Iron to Art, then click on the vendor icon and we will SEE YOU THERE!!

JOIN THE FUN! VOLUNTEER at the Iron to Art Festival. Help out for a while behind the scenes and get a free t shirt! Email exedir@abana.org for more details! Volunteer opportunities, Indoor, outdoor, and tailgating spaces available. <https://abana.org/volunteers-needed/>

Business of Blacksmithing digital class taught by Leigh Morrell

The ABANA Business of Blacksmithing Classes are now complete. We are planning to make the class recordings available to members for purchase at the end of May, AND offer a new series on this topic! Please check our site for more details. If you have any questions, or have an interest in classes like this in the future, please email the Executive Director at exedir@abana.org

Discount Providers

There are several vendors that value us as customers and offer discounts to ABANA Members. The ABANA website has a list of those vendors that we can support while saving a few dollars. There is a new offer, a grinder discount, for ABANA members from Beaumont Metals. See the ABANA site for more details. Please visit www.abana.org to find discounts under the marketplace / vendor page.

ABANA Affiliate Newsletter (Continued)

Share Your Stuff!

Remember ABANA is always willing to share affiliate activities, projects and photos. Send any information to exedir@abana.org

ABANA Affiliate Contest- HAS BEEN EXTENDED!!!!!!

We are offering a GOLDEN OPPORTUNITY for never before ABANA members of our ABANA recognized Affiliate groups to vie for a one year ABANA digital subscription membership, with all the perks. Application and inquiries can be emailed to Chris Rowan the ABANA Affiliate Chairman ironcloverforge@gmail.com with the subject line 'AFFILIATE OPPORTUNITY', also in the body of the email post your Affiliate name and your name. All email applications MUST be submitted by July 4/21 Get your submissions in before the deadline.

*****Also stay tuned for an Affiliate Opportunity to have YOUR Affiliate group build our new Johnstown, PA ABANA Head Office signage to be installed and displayed on our HQ.*****

ABANA is creating a touchmark registry

ABANA is creating a comprehensive registry of touchmarks. To submit your touchmark, please check the ABANA webpage and follow the instructions. <https://abana.org/touchmark-registry/>

Sincerely,

Jerry Boyd
ABANA Affiliates Committee
Shop Helper
325-207-8253

ADDRESS

ABANA Home Office
PO Box 462, Johnstown PA 15907

GET IN TOUCH

Phone: (814) 254-4817
Email: exedir@abana.org

SCABA Shop and Swap

For Sale:

50 Lb Little Giant Power Hammer - Asking \$4,800

In good shape. Owned by me since 1961 or 1962. Has been on loan for several years with limited use and kept well oiled. Currently has a 3 phase motor installed. Located in Wagoner, OK. **Contact William Burling at 918-485-1508.**



For Sale:

Water Jet Services - Saltfork Discount

Taswallson Manufacturing is offering waterjet services at discounted rates for Saltfork members. I am currently operating nights and weekends.

Contact: **Ragnar at rtaswallson@yahoo.com or 918-855-8250.**

2021 Conference T-Shirt

T-Shirts must be pre-ordered. Please place your order by September 24th if you want your shirt at conference.



Back of T-Shirt

Pocket

There are two shirts to choose from this year.

The first is a 50/50 poly cotton blend. This shirt comes in tall sizes.

Port & Company[®] Tall Core Blend Tee. PC55T

Sizes range from Large Tall to 4X Large Tall.

COLOR INFORMATION

Aquatic Blue PMS 2389C	Ash PMS COOL GRAY 3C	Athletic Heather PMS COOL GRAY 7C	Athletic Maroon PMS 209C	Carolina Blue PMS 7692C	Charcoal PMS COOL GRAY 11C	Dark Green PMS 560C	Dark Heather Grey PMS 7540C	Desert Sand PMS 2324C	Jet Black PMS NTR BLACK C	Kelly PMS 340C
Light Blue PMS 278C	Lime PMS 367C	Medium Grey PMS 2337C	Navy PMS 2180C	Orange PMS 177C	Purple PMS 7672C	Red PMS 200C	Royal PMS 2113C	Safety Green PMS 379C	Safety Orange PMS 021 C	Sapphire PMS 2185C
		View the form in the online newsletter or Saltfork website to see the color selection								
White	Yellow PMS 127C									

The second shirt is a tri-blend poly/cotton/rayon shirt. This is a much softer shirt.

BELLA+CANVAS
LOS ANGELES

3413C primeplus
Bella + Canvas Unisex Triblend T-Shirt

Small to 3X: \$15 Each
 4X to 6X: \$20 Each
 5X and 6X are special order and may be a different shirt. Contact Teresa for shirt details:
tgabrish@gmail.com
 405-824-9681

Sizes range from an XS to a 4XL

View the form in the online newsletter or Saltfork website to see the color selection

53 Available Colors

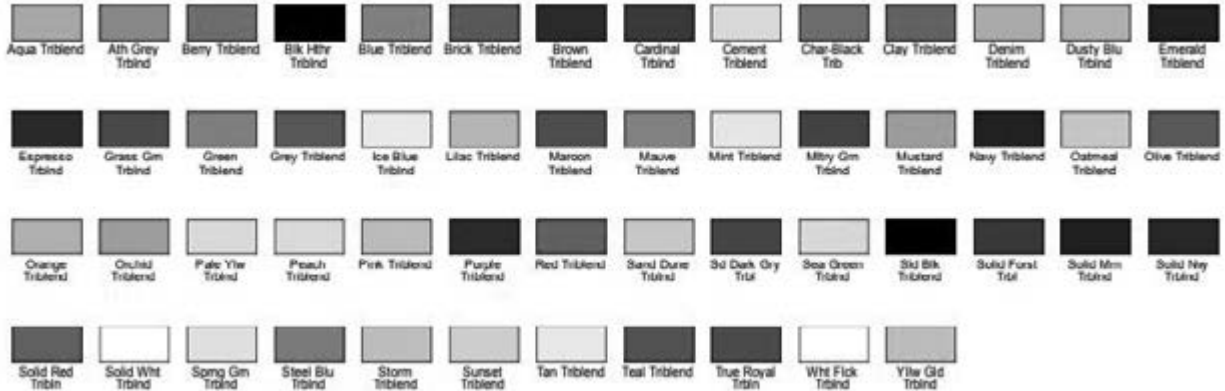

Name: _____ Phone: _____

T-Shirt Style (Port or Bella)	Size	Color	Price	Number	Total

Make Checks Payable to Saltfork Cratsmen Artist Blacksmith Association

Mail to Teresa Gabrish, 23290 NE Wolf Road, Fletcher OK 73541

Shirts will be available to pick up at the Conference. For shirts ordered after the September 24th deadline or to have shirts mailed to you, contact Teresa to arrange shipping.

SCABA Shop and Swap

Wanted to Buy:

I am Saltfork member James Bohrer and I am looking for a powered hacksaw or drawsaw and also line shaft stuff for my forge. The attached photos are the kind of saw I am looking for. Thank you. **Contact James Bohrer at 405-566-8550.**

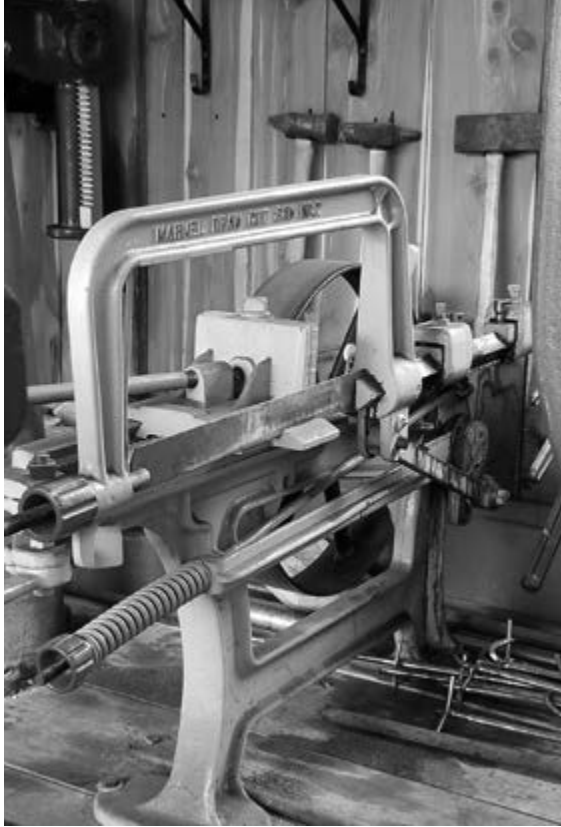

Wanted to Buy:

WANTED: 25LB Little Giant (or similar) Power Hammer. Hoping for a good deal. Not much in the way of cash but will work/barter/trade to offset cost.

Email: Colby.J.C.96@gmail.com or Call/Text me, **Colby Henzel: 918-640-0848.** I get a lot of spam calls so please leave a voicemail if I miss your call. I will return your call ASAP. Thank you.

SCABA Shop and Swap



Your one-stop-shop for
Quick and Rapid Tongs,
blacksmithing tooling,
accessories, apparel, and
the MZ75 Power Hammer.



WWW.KENSIRON.COM

Ken's Custom Iron

37634 County Road 9, Avon, MN 56310 | 320.746.8161 | mail@kensiron.com

SCABA Shop and Swap

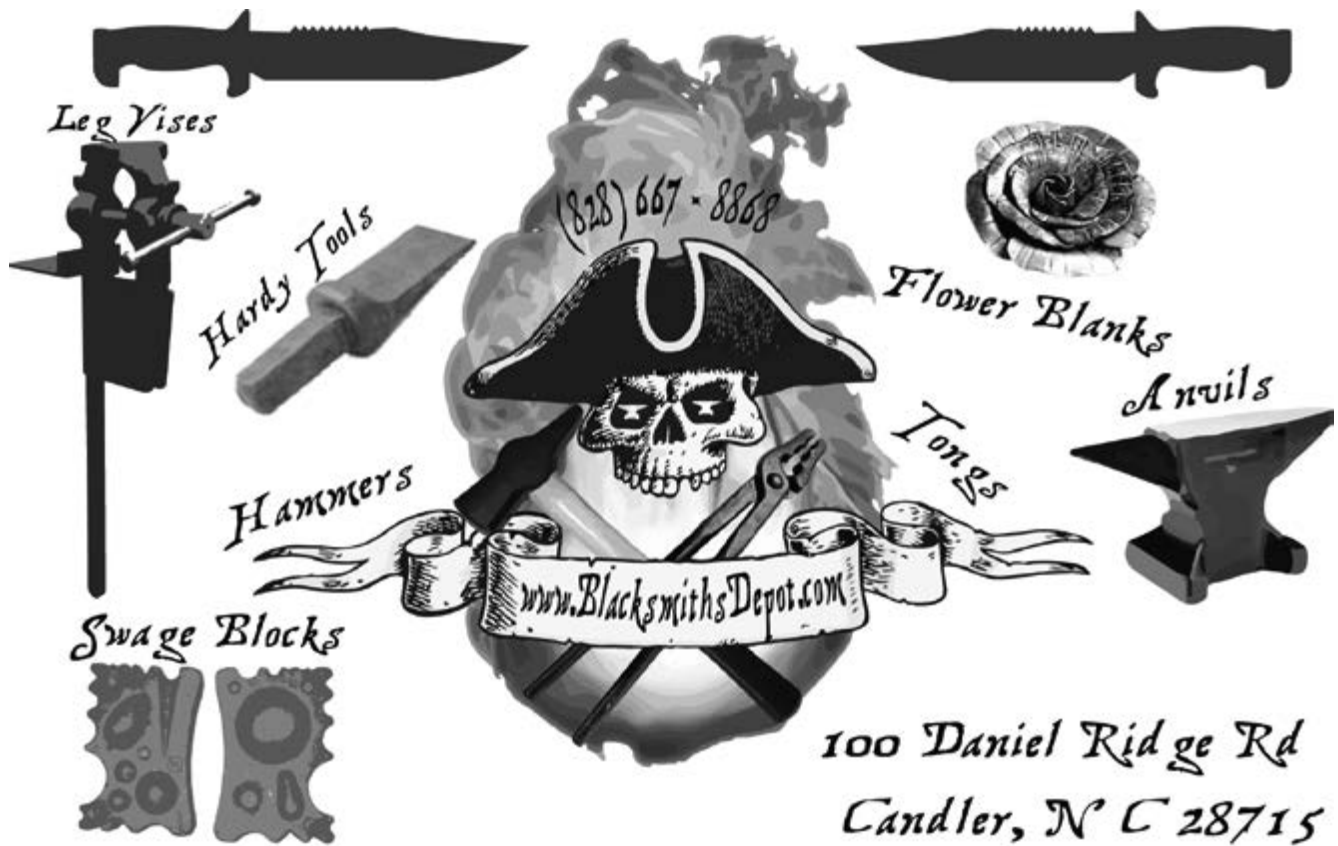

For Sale: 15 Lb Tire Hammers:

\$1,200 for everything from the base plate up. Two rounding dies included as standard. Has 1/2 HP 115V Motor. Contact: David Barfield - 580-595-1476



SCABA Shop and Swap

GET AN APRON THAT
FITS YOU AND
YOUR NEEDS

FORGE-APRONS.COM

KAYNE & Son -- **Blacksmiths Depot**
Custom Hardware, Inc.

100 Daniel Ridge Rd. Candler, N.C. 28715
828-667-8868 fax 828-665-8303

Steve Kayne

- Tools for the Metalworker
- Hammers & Tongs
- Spring Swages & Texture tools
- Anvils, Vices, Slakes and Hardy tools
- Books & Videos
- Specialty Fasteners
- Blacksmithing
- Custom Hinges and Handles
- Thumb latch sets & Lock sets
- Exterior/Interior Hardware
- Builders/Architectural Hardware

BlacksmithsDepot.com - CustomForgedHardware.com



Ken's Custom Iron, LLC

37634 County Road 9
Avon, MN 56310
(320) 746-8161
mail@kensiron.com

Blacksmith Supply
Modern Tool For the Modern Blacksmith
www.blacksmithsupply.com

John Elliott

jelliott@blacksmithsupply.com
804-530-0290

P.O. Box
Chester, VA 23831



Blacksmithsupply
.com

Raker Knives & Steel
Ray Kirk ABS-MS



www.rakerknives.com
gadugiblade@yahoo.com

918-207-8076
Tahlequah, Ok

T STAR LEATHER

Brett Smith
310 E. Fry Terrace
Claremore, OK 74017
410-251-4463
tstarleather@gmail.com
www.TStarLeather.com

Fine Hand Crafted Leather Work
Craftsmanship, Detail, Creativity, Excellence

"T Star Smith"
SASS #72768

SCABA Shop and Swap



Call to Order Toll Free 24/7 - 866-627-6922

Thank you to our Conference Vendors who graciously donated items for the Conference Auctions!

Their contributions helped to support SCABA. Please consider patronizing these vendors to return the favor!



Reeder Products Inc.

3201 Skylane Drive, Suite 114
Carrollton, Texas 75006 United States
(469) 257-1000

Bill Davis Forge Welded Tomahawk DVD

This DVD is now available to members for a minimal cost (cost of DVD's is minimal to cover reproduction and shipping if applicable.) Contact the SCABA Librarian, Don Garner, if you would like to get a copy of this DVD.

Don Garner: 580-302-1845

(Call or Text. If you get voice mail, Please leave a message.)



For Sale:

Tire Hammer Plans by Clay Spencer

Send a check or money order for \$30 US to Clay Spencer, 73 Penniston Pvt. Drive, Somerville, AL 35670-7013. Or send \$32 US to Paypal.Me/ClaySpencer. E-mail me at clay@otelco.net. PDFs will be e-mailed outside US. Phone 256-558-3658

Beverly shear blades sharpened

Remove your blades and send in USPS small flat rate box with check for \$41 US to 73 Penniston Pvt. Drive, Somerville, AL 35670-7103.

For Sale: I have numerous old tools and collectible items of various kinds including blacksmith related tools and equipment. Too many tools to list them all. Inventory is always changing. Contact: Craig Guy (SCABA Member), Piedmont, OK
Cell Phone: 405-630-7769 (Call or Text)

SCABA Shop and Swap

SCABA Library DVD's Available:

This is a partial list of the DVD titles available to members from the SCABA Library. Contact the Librarian (Don Garner) if you would like to obtain a copy of any listed title or if you have questions on any other titles that may be available. Additional titles are listed on the website. DVD's are available for a very minimal cost to offset the blank disc and cases or sleeves. Shipping cost applies if you need these delivered by mail.

- Robb Gunter Basic Blacksmithing parts 1,2,3 and the controlled hand forging series
- Clay Spencer SCABA conf.2013 pts. 1,2 and 3
- Jerry Darnell 18th century lighting, door latches and hinges
- Brent Baily SCABA conf. 2011
- Mark Aspery SCABA conf. 2011
- Robb Gunter SCABA conf. 1998
- Robb, Brad and Chad Gunter 2009 joinery, forging, repousse, scrollwork, etc.
- Bill Bastas SCABA 2002 pts. 1 - 6
- Jim Keith SCABA conf.2007
- Power hammer forging with Clifton Ralph pts. 1 - 5
- Doug Merkel SCABA 2001
- Bob Alexander SCABA 2008
- A. Finn SCABA 2008
- Bob Patrick SCABA 2004
- Gordon Williams SCABA 2010
- Daryl Nelson SCABA 2010
- Jim and Kathleen Poor SCABA 2001
- Ed and Brian Brazeal SCABA 2006
- Ray Kirk Knives SCABA 2002
- Frank Turley SCABA 1997
- Frank Turley SCABA 2003
- Bill Epps SCABA 2003
- M. Hamburger SCABA 2007

Librarian: Don Garner 580-302-1845 (Cell)
Call or Text. If you get voice mail, please leave a message.

Have an Item for Sale? Item Wanted?

If you have any items that are appropriate for Blacksmiths that you would like to list in the Shop and Swap section (or items you are looking for), please send me your description, contact info, and any photos that you have.

SCABA Swage Blocks

**** (NOTICE: Price Change) ****

\$250.00 plus shipping.

(Same price to members and non-members.)

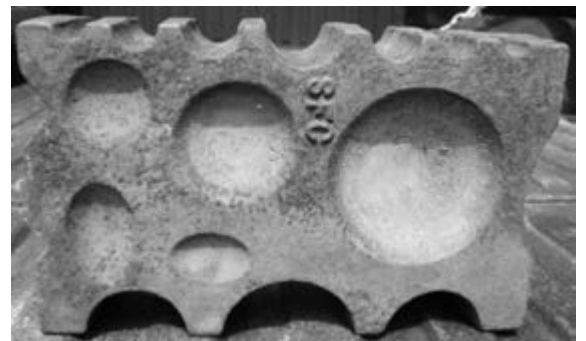
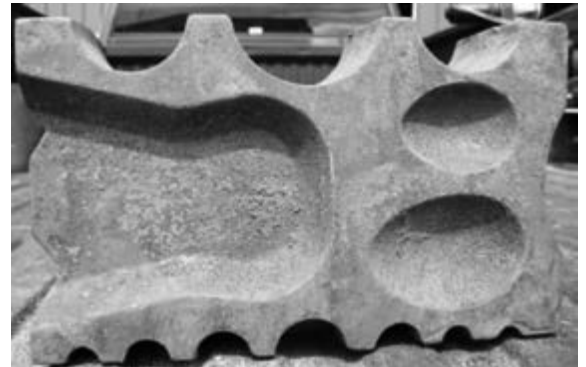

SCABA Floor Cones



\$275.00 plus shipping.

(Same price to members and non-members.)

To order swage blocks or cones, contact our distributor:

**Nolan Walker at
Nature Farms Farrier
Supply in Norman,
OK.**

405-307-8031

SCABA Shop and Swap

Club Coal:

**** (NOTICE: Price Change) ****

Saltfork Craftsmen has coal for sale. Coal is in 1-2" size pieces. The coal is \$300.00/ton or .15 /pound to members.

No sales to non-members.

NW Region coal pile located in Douglas, OK. If you make arrangements well in advance, Tom Nelson can load your truck or trailer with his skid steer loader for a fee of \$10 to be paid directly to Tom. Tom has moved his skid steer and must now haul the loader to the coal pile to load you out, hence the \$10 charge. You may opt to load your own coal without using Tom's loader. The coal can be weighed out at the Douglas Coop Elevator scales. Contact Tom Nelson (580-862-7691) to make arrangements to pick up a load. Do not call Tom after 9 PM!! Bring your own containers and shovels. Payment for the coal (\$.15 per pound) should be made directly to the Saltfork Treasurer.

NW Region Coal Pile in Thomas:

Don Garner now has a new pile of club coal available for sales to SCABA members. The shop is at 23713 E 860 Rd in Thomas, OK. (One mile west, then one mile north of Thomas.) Contact Don at 580-302-1845 (Cell Phone) to arrange details for purchases.

NE Region coal location:

****NOTICE:****

Charlie McGee is no longer hosting the coal pile in the NE region. If you would be interested in hosting a location in NE, let one of the SCABA Board members know.

S/C region coal location: Club coal is now available at Norman at Byron Doner's place. Call Byron to make arrangements to come by and get coal.

SCABA T-Shirts!

2018 Saltfork Collector T-shirts are available with the 2018 Conference Logo. \$5.00 (plus shipping if applicable.) Contact Josh Perkins to check sizes and quantities that are still available.



Legacy SCABA T-shirts and long sleeve denim shirts are also available on clearance while supplies last. T-Shirts are \$5.00 and Denim Shirts are \$10.00. (Plus shipping if applicable.) Contact Josh Perkins to check sizes and quantities that are still available.

If you would like to purchase shirts, contact Josh Perkins (918) 269-3523.



Have an Item for Sale? Item Wanted?

If you have any items that are appropriate for Blacksmiths that you would like to list in the Shop and Swap section (or items you are looking for), please send me your description, contact info, and any photos that you have.



SCABA Membership Application

For Annual Membership

(Please Print Clearly!)

Date _____

New Member	_____
Renewal	_____

First Name _____ Last Name _____

Married? _____ Yes _____ No _____ Spouse's Name _____

Address _____

City _____ State _____ Zip _____

Phone (Best Number to Contact) (_____) _____

e-mail _____

Newsletter Preference:	
<input type="checkbox"/>	No Print Copy
<input type="checkbox"/>	E-mail Alerts for New Newsletters

ABANA Member? _____ Yes _____ No _____

I have enclosed \$30.00 for dues for one year membership from the date of acceptance.

Signed: _____

Return to: Saltfork Craftsmen, 6520 Alameda, Norman, OK 73026

Note: Registration online by Paypal OR credit card is available from the website.

www.saltforkcraftsmen.org

You do NOT need a Paypal account to use your credit card and registration/renewal is immediate.



Saltfork Regional Meeting Hosting Form

Region: _____ NE _____ SE _____ SW _____ NW

Date: Month _____ Day _____ Year _____

Name: _____

Meeting Address: _____

Host Phone (Best Number to Contact) (_____) _____

Host e-mail _____

Trade Item: _____

Lunch Provided: _____ Yes _____ No

Please provide detailed directions and/or a map to meeting location if possible. Meetings are scheduled on a first come basis.

Return to: Saltfork Craftsmen Regional Meeting Coordinator, Russell Bartling

70 N 160th W Ave

Sand Springs, OK 74063

You can also send the information in an e-mail or text or fill out the online form available on the website in the top banner of the Calendar Tab: www.saltforkcraftsmen.org/Calendar.shtm

Saltfork Craftsmen Artist Blacksmith Assoc. Inc.
6520 Alameda
Norman, OK. 73026

Non Profit Organization
U S Postage Paid
Oklahoma City, Ok
Permit #2177

Address Service Requested

